

CAN-AM CHAINS PRODUCTS



EUROPEAN METRIC VERSION

USA

HEAD OFFICE USA

15151 S.E. Minuteman Way
P.O. Box 453
Clackamas, OR 97015
Phone (503) 657-1158
Fax (503) 656-7549
Toll Free 1-800-547-6274

SHREVEPORT BRANCH

2095 N. Hearne Ave.
Shreveport, LA 71107
Phone (318) 227-8006
Fax (318) 424-7751
Toll Free 1-800-321-8846

ALABASTER BRANCH

600 Galloway Circle
Alabaster, AL 35007
Phone (205) 942-2617
Fax (205) 942-4975
Toll Free 1-800-824-0674

ROCKY MOUNT BRANCH

7010 Stanley Park Dr.
Rocky Mount, NC 27804
Phone (252) 451-0636
Fax (252) 451-0833
Toll Free 1-888-856-0744

e-mail: usasales@can-amchains.com

CANADA

HEAD OFFICE CANADA

8355 128th Street
Surrey, BC V3W 4G1
Phone (604) 599-1522
Fax (604) 599-4115
Shipping (604) 594-5811
Toll Free 1-800-663-3136

BRITISH COLUMBIA BRANCH

9661 Penn Road
Prince George, BC V2N 5T6
Phone (250) 562-7727
Fax (250) 562-9603
Toll Free 1-877-399-3136

ALBERTA BRANCH

Unit 5 - 2002 8th Street
Nisku, Alberta T9E 7Y8
Phone (780) 955-3993
Fax (780) 955-3994
Toll Free 1-800-832-7556

ONTARIO BRANCH

5050 Dufferin Street
North York, Ontario M3H 5T5
Phone (705) 647-5366
Fax (705) 647-5323
Toll Free 1-800-265-3582

e-mail: cansales@can-amchains.com

EUROPE

HEAD OFFICE EUROPE

Unit 11 Kingfisher Boulevard
Newburn Riverside
Newcastle Upon Tyne
NE15 8NZ
Phone +44 (0) 191 229 0800
Fax + 44 (0) 191 908 7371

e-mail: europesales@can-amchains.com

CHILE

COMERCIALIZADORA CAM-CHAIN CHILE LIMITADA

Camino a Vertedero Concepción
N* 20-A (km 3.5 Ruta 150) Penco,
Chile
Phone +56 41 285 3881
56 41 285 3885
Fax +56 41 275 1528

e-mail: camchainchile@can-amchains.com

ROLLER CHAINS	4
Chain Components	5
British Standard	6
American Standard	7
Heavy Series Chains	8
Stainless Steel Chains	9
Sharp Top Chains	11
WELDED CHAINS	12
Chain Designation	13
Mill Chains	14
Mill Chain Attachments	17
Drag Chains	26
Drag Chain Attachments	30
Malleable Chains	32
Power Transmission	34
Trimmer Chains	34
Trimmer Chain Attachments	35
Mill Chain Rivets	37
OSB Chains	38
Special Chains	40
Engineered Class Chain	42
Bucket Elevator Chain	43
Formed Steel Pintle	44
Rivetless Chains	46
142 Series – Cdm Systems Chain	48
142 Triple Series	49
142 Double Series – Cdm Systems Chain	50
102 & 142 Flights – Cdm Systems Chain	51
LEAF CHAINS	52
AL And BL Series	52
ENGINEERED PLASTICS	54
Nyro-PVL	54
Can-Am "ICE"	54
MAGNA-SKIN	55
Magna-Plate™	55
Magna-Wedge™	55
BEARINGS	56
2500 Series Bearings	56
1000 Series Bearings	57
Bearing Load Rating	57
SPROCKETS	59
Mill Chain Sprockets	59
Drag Chain Sprockets	60
Sprocket Information Guide	61
TECHNICAL SECTION	62



Connecting Link Spring Lock Type

The two pins and one link plate are furnished assembled. The standard coverplate is designed for a split-fit on the pins. It is held in place by a flat spring-steel lock, split at one end to permit installation in grooves at the end of each pin. Press-fit coverplates are also available and are recommended for heavy duty applications.



Connecting Link Cotter Pin Type

The two pins and one link plate are furnished assembled. The coverplate may be either press-fit or slip-fit on the pins. Press-fit connecting links are recommended for heavy duty applications. Press-fit coverplates are standard on multiple strand oil field chains.

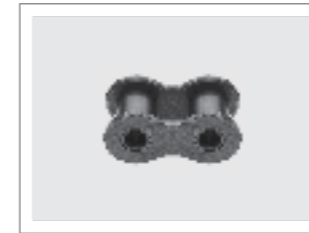

Roller Link

Standard for all sizes of roller chains. They are furnished as complete roller link assemblies. The two bushings are press-fit in each of the link plates. The same roller link are used for single and multiple strand chains.



Single-Pitch Offset Link Slip-Fit Type

This link is furnished with slip-fit pin unassembled in the offset link plates. The flat milled on one end of the pin prevents it from turning in the link plate.



Two-Pitch Offset Assembly Press-Fit Type For Single Strand Chain Only

This type of assembly is available for all sizes of standard single strands chains, and consists of an offset link and roller link assembled together. The pin is press-fit in the offset link plates and is riveted. The press-fit construction of this assembly greatly increases its structural rigidity, reliability, and durability. For these reasons, the two-pitch offset link is recommended in preference to the single-pitch offset link.

Heavy Series Chains

Heavy Series chains, also built in accordance with ANSI B29.1, are designed using link plate material from next larger size chain. Heavy Series chain are not necessarily stronger than Standard Series chains, but the thicker link plate material provides an increase in fatigue resistance for those drives subjected to heavy shock loads, multiple stops/starts or reversing.

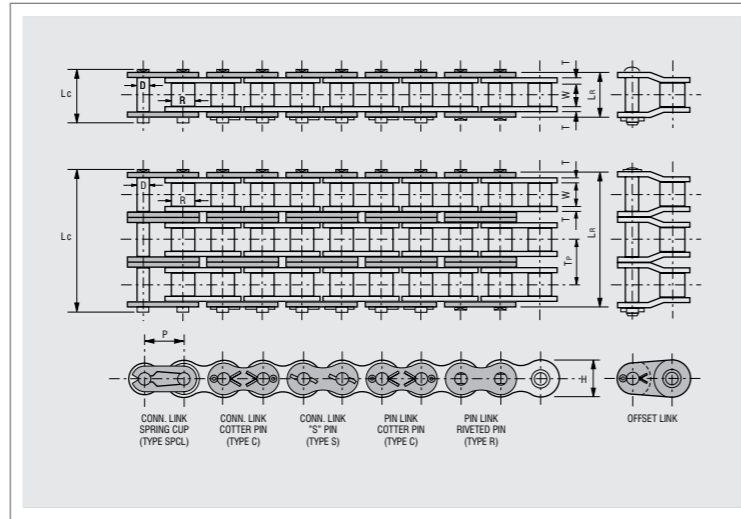

ANSI Number	Pitch		Roller Width	Roller Diameter	Pin Diameter	Plate Thickness	Lc	Lr	Tp	Average Weight	Average Tensile Strength
	P	W	R	D	T						
mm											
60H-1	19.050	12.700	11.913	5.944	3.175	31.496	29.718	—	1.760	37,808	
60H-2	19.050	12.700	11.913	5.944	3.175	57.658	55.880	26.111	3.470	75,616	
60H-3	19.050	12.700	11.913	5.944	3.175	84.074	82.296	26.111	5.160	113,424	
60H-4	19.050	12.700	11.913	5.944	3.175	110.236	108.204	26.111	6.860	151,232	
80H-1	25.400	15.875	15.875	7.925	3.962	39.878	36.830	—	3.050	64,446	
80H-2	25.400	15.875	15.875	7.925	3.962	72.136	69.088	32.588	5.850	128,992	
80H-3	25.400	15.875	15.875	7.925	3.962	105.156	102.108	32.588	8.810	193,488	
80H-4	25.400	15.875	15.875	7.925	3.962	137.668	134.620	32.588	11.710	257,984	
100H-1	31.750	19.050	19.050	9.525	4.750	47.244	44.196	—	4.200	106,752	
100H-2	31.750	19.050	19.050	9.525	4.750	86.614	83.312	39.091	8.300	213,504	
100H-3	31.750	19.050	19.050	9.525	4.750	125.730	122.428	39.091	12.380	320,256	
100H-4	31.750	19.050	19.050	9.525	4.750	164.846	161.798	39.091	16.430	427,008	

Stainless Steel Chains

300 Series Stainless Chains are assembled entirely from 300 Series (austenitic) components. They have excellent corrosion resistance and very low magnetic permeability but cannot be expected to have same wear resistance of our heat treated stainless chains. For industries that required it, 300 Series chain can be considered "non-sparking".

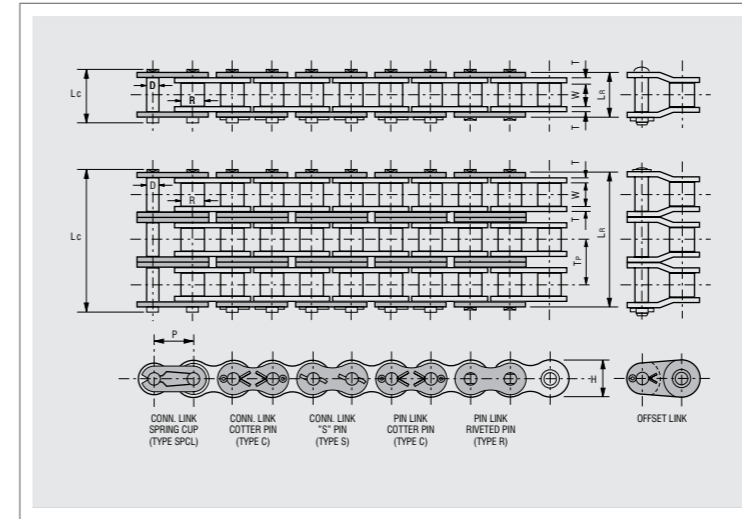

American Standard

ANSI Number	Pitch		Roller Width	Roller Diameter	Pin Diameter	Plate Thickness	Lc	Lr	Tp	Average Weight	Average Tensile Strength
	P	W	R	D	T						
mm											
35-1SS	9.525	4.763	*5.080	3.581	1.270	14.224	12.700	—	.310	7,562	
40-1SS	12.700	7.938	7.925	3.962	1.524	18.288	17.018	—	.610	13,344	
40-2SS	12.700	7.938	7.925	3.962	1.524	32.766	31.496	14.376	1.184	26,800	
41-1SS	12.700	6.350	7.772	3.581	1.270	16.510	14.478	—	.420	7,562	
50-1SS	15.875	9.525	10.160	5.080	2.032	22.606	21.082	—	1.010	20,906	
50-2SS	15.875	9.525	10.160	5.080	2.032	40.640	39.370	18.110	1.954	42,100	
60-1SS	19.050	12.700	11.913	5.944	2.388	28.194	26.416	—	1.490	30,024	
60-2SS	19.050	12.700	11.913	5.944	2.388	51.054	49.276	22.784	2.890	60,500	
80-1SS	25.400	15.875	15.875	7.925	3.175	36.576	33.528	—	2.570	53,376	

* Chains are rollerless – dimensions shown is bushing diameter.

British Standard

ISO/DIN BS Number	Pitch	Roller Width	Roller Diameter	Plate Height	Pin Diameter	Lc	Lr	Tp	Average Weight	Average Tensile Strength
	P	W	R	H	D					
mm										
05B-1SS	8.000	3.000	5.000	7.100	2.310	11.700	8.600	—	0.390	3,500
06B-1SS	9.525	5.720	6.350	8.200	3.280	16.800	13.500	—	0.440	6,650
06B-2SS	9.525	5.720	6.350	8.200	3.280	27.100	23.800	10.240	0.740	10,500
06B-3SS	9.525	5.720	6.350	8.200	3.280	37.300	34.000	10.240	1.110	17,850
08B-1SS	12.700	7.750	8.510	11.800	4.450	20.900	17.000	—	0.700	12,000
08B-2SS	12.700	7.750	8.510	11.800	4.450	34.900	31.000	13.920	1.400	22,000
08B-3SS	12.700	7.750	8.510	11.800	4.450	48.800	44.900	13.920	1.310	35,300
10B-1SS	15.875	9.650	10.160	14.700	5.080	23.700	19.600	—	0.920	15,000
10B-2SS	15.875	9.650	10.160	14.700	5.080	40.300	36.200	16.590	3.000	28,450
10B-3SS	15.875	9.650	10.160	14.700	5.080	56.900	52.800	16.590	1.790	42,650
12B-1SS	19.050	11.680	12.070	16.100	5.720	27.300	22.700	—	1.120	17,000
12B-2SS	19.050	11.680	12.070	16.100	5.720	46.800	42.200	19.460	2.210	37,250
12B-3SS	19.050	11.680	12.070	16.100	5.720	66.300	61.700	19.460	2.220	50,050
16B-1SS	25.400	17.020	15.880	21.000	8.270	41.500	36.100	—	2.590	40,000
16B-2SS	25.400	17.020	15.880	21.000	8.270	73.400	68.000	31.880	5.080	74,450
16B-3SS	25.400	17.020	15.880	21.000	8.270	105.300	99.900	31.880	5.030	117,600

All Can-Am Sharp Top Chains exceed ANSI and BRITISH STANDARDS and are exact replacements for new and existing Sharp Top Roller Chain applications. Can-Am Chain is competitively priced and readily available for any standard applications. Custom designed systems are also available.

Can-Am Sharp Top Roller Chain Features:

- Fine blanked side plates
- Heat treated shot peened bushing and plates for higher fatigue strength
- Triple alloy steel rivet pins with heavy case depth
- Ballized bushed plates for uniform hole size
- Heavy pressed fit for pins and bushings
- Factory lubricated for extended chain life
- Optional Induction hardened teeth
- Optional machined bottom

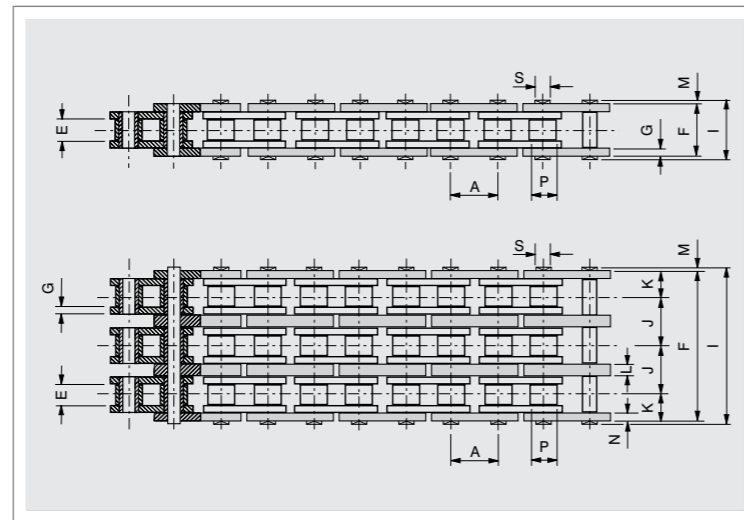

2-POINT (SLL) SERIES – "SLASHER LOW PROFILE"

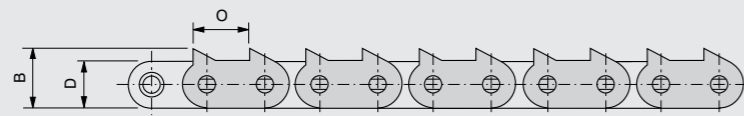

3-POINT (ST) SERIES

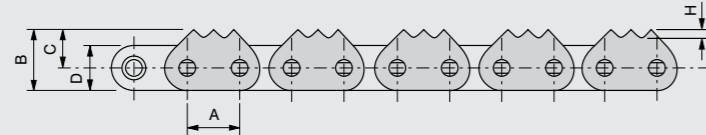

4 PEP – (4 POINT EVERY PITCH)

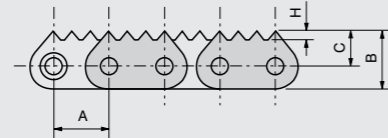

5 PEP SERIES – (5 POINT EVERY PITCH)

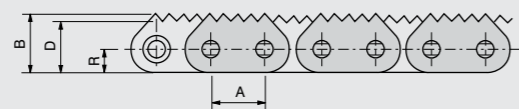

W4P SERIES – WAFERIZER CHAIN

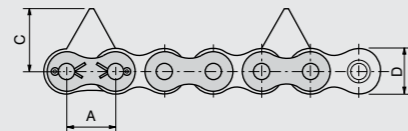

160-1-DP SERIES, 32B-1 SERIES Narrow Series, 32B-1 SERIES Standard Series

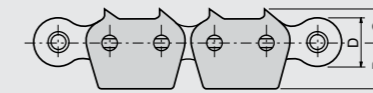

AMERICAN STANDARD

Chain Number	A	B	C	D	E	F	G	H	I	J	K	L	M	N	O	P	R	S	
	mm																		
60-1 ST	19.050	21.590	13.005	17.501	12.700	22.301	2.388	2.388	25.400	-	-	-	-	-	-	-	-	-	-
60-2 ST	19.050	21.692	12.954	17.399	12.700	45.060	2.388	2.388	48.260	22.809	12.700	-	-	-	-	-	-	-	-
80-1 ST	25.400	28.956	17.399	23.216	15.799	28.702	3.175	3.175	32.385	-	-	-	-	-	-	-	-	-	-
80-2 ST	25.400	28.956	17.399	23.216	15.875	58.674	3.175	3.175	61.468	29.286	16.002	6.325	-	-	-	-	-	-	-
80-3 ST	25.400	28.956	17.399	23.216	15.875	87.884	3.175	3.200	90.932	29.286	16.510	6.350	-	-	-	-	-	-	-
80-4 ST	25.400	28.956	17.399	23.216	15.875	117.196	3.175	3.200	120.396	29.286	16.383	6.350	-	-	-	-	-	-	-
100-1 ST	31.750	33.655	19.050	29.007	18.059	34.900	3.962	3.175	39.218	-	-	-	-	-	-	-	-	-	-
100-2 ST	31.750	33.655	18.161	29.134	19.050	71.247	3.962	3.175	75.006	35.789	19.609	7.874	-	-	-	-	-	-	-
100-3 ST	31.750	33.655	19.152	29.134	19.050	106.680	3.962	3.200	110.795	35.789	19.609	7.874	-	-	-	-	-	-	-
120-1 ST	38.100	40.488	23.089	34.798	25.400	44.450	4.750	3.175	49.327	-	-	-	-	-	-	-	-	-	-
120-2 ST	38.100	40.488	23.089	34.798	25.400	83.820	4.750	3.175	94.717	45.390	24.638	10.414	-	-	-	-	-	-	-
120-4 ST	38.100	40.488	23.089	34.798	25.400	181.610	4.750	3.175	185.496	45.390	24.638	10.414	-	-	-	-	-	-	-
80-1 SLL	25.400	29.515	-	23.393	15.875	34.188	3.175	-	34.188	-	-	-	1.524	3.962	25.400	-	-	-	-
80-2 SLL	25.400	29.515	-	23.393	15.875	60.122	3.175	-	29.286	-	6.350	1.524	3.962	25.400	-	-	-	-	-
80-3 SLL	25.400	29.515	-	23.393	15.875	89.408	3.175	-	29.286	-	6.350	1.524	3.962	25.400	-	-	-	-	-
80-4 SLL	25.400	29.515	-	23.393	15.875	118.694	3.175	-	29.286	-	6.350	1.524	3.962	25.400	-	-	-	-	-
100-1 SLL	31.750	35.611	-	30.048	19.050	-	3.988	-	40.589	-	-	-	-	4.801	-	19.050	1.499	-	-
100-2 SLL	31.750	35.611	-	30.048	19.050	-	3.988	-	78.410	35.763	-	7.747	-	4.801	-	19.050	1.499	-	-
100-3 SLL	31.750	35.611	-	30.048	19.050	112.319	3.988	-	35.763	-	7.747	-	-	4.801	-	19.050	1.499	-	-
80-2 (5 PEP)	25.400	29.007	-	26.111	15.875	58.395	3.175	-	29.286	-	6.350	1.524	3.175	-	-	-	-	11.608	-
80-3 (5 PEP)	25.400	29.007	-	26.111	15.875	87.884	3.175	-	29.286	-	6.350	1.524	3.175	-	-	-	-	11.608	-
80-4 (5 PEP)	25.400	29.007	-	26.111	15.875	117.881	3.175	-	29.286	-	6.350	1.524	3.175	-	-	-	-	11.608	-
80-3-W2P	25.400	-	31.750	23.368	15.875	-	3.175	-	93.802	29.210	18.009	-	-	-	-	-	-	-	-
80-3-W4P	25.400	-	31.750	23.368	15.875	-	3.175	-	93.802	29.210	18.009	-	-	-	-	-	-	-	-
160-1-DP	50.800	-	33.045	46.990	31.750	58.293	6.350	-	-	-	-	-	2.540	6.350	-	28.575	45.009	14.275	-
80-2-4 PEP	25.400	26.492	16.002	-	15.875	58.598	3.175	3.810	61.620	29.261	-	6.350	1.524	3.200	-	-	-	-	-

BRITISH STANDARD – 5 PEP SERIES

Chain Number	A	B	D	E	F	I	J	P
	mm							
12B-1	19.05	21.100	12.350	11.700	22.710	27.310	-	12.100
12B-2	19.05	21.100	12.350	11.700	42.190	46.310	19.500	12.100
16B-1	25.400	26.500	21.100	17.000	33.500	38.890	-	17.000
16B-2	25.400	26.500	21.100	17.000	67.990	73.410	31.880	17.000
20B-1	31.800	32.800	26.420	19.600	43.210	49.300	-	19.600
20B-2	31.800	32.800	26.420	19.600	79.710	85.800	36.450	19.600
24B-1	38.100	38.500	33.400	25.400	53.390	59.990	-	25.400
24B-2	38.100	38.500	33.400	25.400	101.800	108.400	48.360	25.400

BRITISH STANDARD – 32B-1 SERIES NARROW AND STANDARD SERIES

Chain Number	A	C	D	E	P	R
	mm					
32B-1 Narrow	50.800	29.997	40.996	17.018	29.210	44.983
32B-1 Standard	50.800	29.997	40.996	30.988	29.210	44.983



SIDE BAR



THROUGH HARDENED 32-36 Rc
INDUCTION HARDENED 48-55 Rc

RIVET

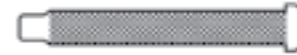

INDUCTION HARDENED ZONE - .100 DEEP
50-55 Rc

BARREL



INDUCTION HARDENED ZONE 40-45 Rc

Due to increasing demand from our customers and our commitment to serving the industry, we have broadened our selection base and to achieve this effectively, we have adopted the following National Standard Chain Designation:

WR – Welded steel chain c/w heat treated rivets

WH – Welded steel chain – fully heat treated

WHIBR – Fully heat treated plus further Induction Hardened Barrels & Rivets

WHIBRS – Same as IBR plus sidebar wear surfaces

WD – Welded steel drag chain

XHD – Extra heavy duty

CS – Cast steel barrel

NOTE: Unless otherwise specified (quoted) welded steel chains are always supplied in 10 ft. lengths.

THROUGH HEAT TREATING & INDUCTION HARDENING

(IBR) denotes fully heat treated & induction hardened barrels & rivets.

(IBRS) denotes fully heat treated & induction hardened barrels, rivets & side bars.

Used individually or combined the two types of heat treating CAN-AM chain can dramatically increase chain life.

IMPACT & STRENGTH

Through heat treated chain (to the proper hardness) will improve impact and ultimate strength.

WEAR

In a non-abrasive environment heat treated chain will give up to 50% greater wear life. Reduction of elongation of side bar holes can be assisted by induction hardening the hole perimeter.

In a non-abrasive environment, induction hardened chain will give several times greater wear life.

NOTE: Individual situations may vary wear life!

Induction hardening depth and Rc range will vary to suit thickness of material, diameter of rivets and particular applications.

HEAT TREATED AND INDUCTION HARDENED CHAIN

CAN-AM welded steel chains are available from stock with fully heat treated parts and/or induction hardened parts. For maximum chain life in severe applications including heavy impact loading, high speed requirements, capacity loads, or abrasive conditions, some or all of your CAN-AM chain will benefit from specific heat treatment.

OFFSET SIDEBAR WELDED STEEL CHAIN

CAN-AM WELDED STEEL CHAINS provide an economical and superior method for conveying most materials. They are most common in the lumber, pulp and paper, plywood, OSB and other board mills, bucket elevator and bulk material handling.

For higher impact strength and greater wear resistance, use fully heat treated or induction hardened chain.

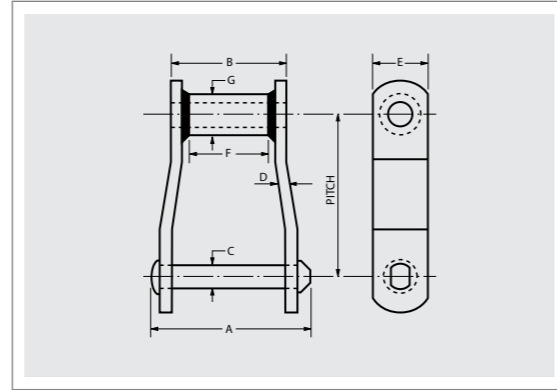

Chain Number	Pitch	Ultimate Strength	Allowable Working Load	Links	Average Weight	Approx. Overall Width	Length of Bearing	Rivet Dia.	Side Bar Thickness	Side Bar Height	Approx. Tooth Face at Pitch Line	Outside Barrel Dia.
						A	B	C	D	E	F	G
	mm	Kg		Pcs./Mtr	Kg/Mtr	mm						
WR-78	66.269	12,247	2,041	15.1	6.4	76.2	50.8	12.7	6.4	31.8	25.4	21.3
WH-78	66.269	14,969	2,495	15.1	6.4	76.2	50.8	12.7	6.4	31.8	25.4	21.3
WR-78-4	101.600	12,247	2,041	9.8	5.2	76.2	50.8	12.7	6.4	31.8	25.4	21.3
WR-82	78.105	13,608	2,268	12.8	7.0	85.7	57.2	14.2	6.4	31.8	28.6	25.4
WH-82	78.105	16,330	2,722	12.8	7.0	85.7	57.2	14.2	6.4	31.8	28.6	25.4
WR-124	101.600	22,861	3,720	9.8	11.6	108.0	69.9	19.1	9.5	38.1	38.1	31.8
WH-124	101.600	25,855	4,309	9.8	11.6	108.0	69.9	19.1	9.5	38.1	38.1	31.8
WR-111	120.904	22,861	4,309	8.2	12.8	122.2	85.7	19.1	9.5	44.5	44.5	31.8
WH-111	120.904	27,216	5,443	8.2	12.8	122.2	85.7	19.1	9.5	44.5	44.5	31.8
WR-106	152.400	22,861	3,720	6.6	9.2	108.0	69.9	19.1	9.5	38.1	38.1	31.8
WH-106	152.400	27,216	5,443	6.6	9.2	108.0	69.9	19.1	9.5	38.1	38.1	31.8
WR-132	153.670	38,783	6,396	6.6	21.0	161.9	111.9	25.4	12.7	50.8	69.9	44.5
WH-132	153.670	55,339	9,208	6.6	21.0	161.9	111.9	25.4	12.7	50.8	69.9	44.5
WR-150	153.670	54,432	8,618	6.6	24.3	165.1	111.9	25.4	12.7	63.5	69.9	44.5
WH-150	153.670	55,339	9,208	6.6	24.3	165.1	111.9	25.4	12.7	63.5	69.9	44.5
WR-155	153.670	67,133	9,979	6.6	28.3	162.7	112.7	28.6	14.3	63.5	69.9	44.5
WH-155	153.670	79,380	13,154	6.6	28.3	162.7	112.7	28.6	14.3	63.5	69.9	44.5
WR-157	153.670	67,133	9,979	6.6	29.8	171.5	117.5	28.6	15.9	63.5	69.9	44.5
WH-157	153.670	79,380	13,154	6.6	29.8	171.5	117.5	28.6	15.9	63.5	69.9	44.5
WR-159	155.575	83,916	12,701	6.6	38.7	171.5	117.5	31.8	15.9	76.2	69.9	48.3
WH-159	155.575	95,256	14,515	6.6	38.7	171.5	117.5	31.8	15.9	76.2	69.9	48.3
WR-200	155.575	83,916	12,701	6.6	32.9	171.5	117.5	31.8	15.9	63.5	69.9	48.3
WH-200	155.575	86,184	14,515	6.6	32.9	171.5	117.5	31.8	15.9	63.5	69.9	48.3

All of the above CAN-AM chains are standard with heat treated rivets. For WH144 and WH166, please refer to OSB Chains, page 38. Note: For extra heavy duty chains see page 16.

STRAIGHT SIDEBAR WELDED STEEL CHAIN

CAN-AM WELDED STEEL C CLASS CHAINS provide easy access for welding attachments to CAN-AM Steel chain, especially for field welding.

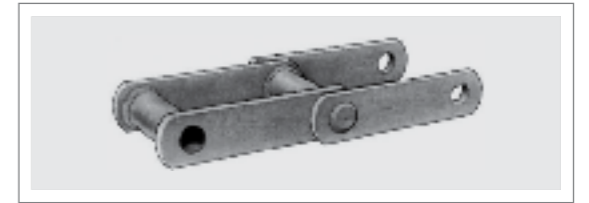
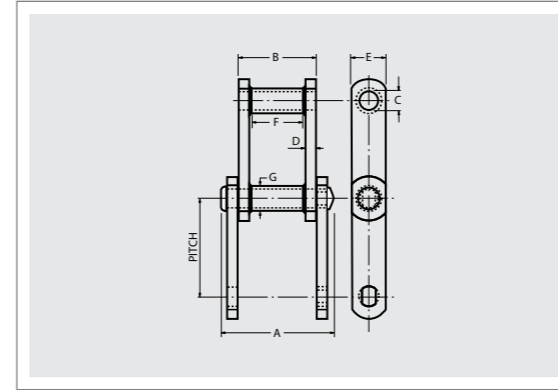

Chain Number	Pitch	Ultimate Strength	Allowable Working Load	Links	Average Weight	Approx. Overall Width	Length of Bearing	Rivet Dia.	Side Bar Thickness	Side Bar Height	Approx. Tooth Face at Pitch Line	Outside Barrel Dia.
						A	B	C	D	E	F	G
	mm	Kg		Pcs./Mtr	Kg/Mtr	mm						
WRC78	66.269	12,247	2,041	15.1	6.4	76.2	50.8	12.7	6.4	31.8	25.4	21.3
WRC82	78.105	13,608	2,268	12.8	5.2	85.7	57.2	14.3	6.4	31.8	25.4	21.3
WRC131*	78.105	22,861	3,810	12.8	10.1	90.5	50.8	19.1	9.5	38.1	25.4	31.8
WRC124	101.600	22,861	3,810	9.8	11.6	108.0	69.9	19.1	9.5	38.1	38.1	31.8
WRC111	120.904	22,861	3,810	8.2	12.8	122.2	85.7	19.1	9.5	44.5	44.5	31.8
WRC110	152.400	22,861	3,810	6.6	10.7	108.0	69.9	19.1	9.5	38.1	38.1	31.8
WRC132	153.670	38,783	6,396	6.6	21.0	165.1	111.9	25.4	12.7	50.8	69.9	44.5
WRC150	153.670	54,432	8,618	6.6	24.3	165.1	111.9	25.4	12.7	63.5	69.9	44.5
WRC157	153.670	56,700	9,979	6.6	31.3	171.5	117.5	28.6	15.9	63.5	69.9	44.5

*Fits in 4" channel

EXTRA HEAVY-DUTY WELDED STEEL CHAIN

CAN-AM EXTRA HEAVY DUTY WELDED STEEL CHAINS provide higher ultimate strength, superior impact resistance and longer life than standard chains. The CAN-AM Tough Guy features include: greater impact capabilities, higher ultimate strength and larger wearing surface.

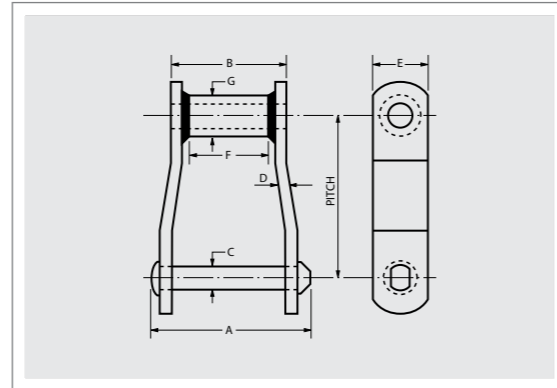

Chain Number	Pitch	Ultimate Strength	Allowable Working Load	Links	Average Weight	Approx. Overall Width	Length of Bearing	Rivet Dia.	Side Bar Thickness	Side Bar Height	Approx. Tooth Face at Pitch Line	Outside Barrel Dia.
						A	B	C	D	E	F	G
						mm						
WR-78XHD*	66.954	16.330	2,722	15.1	9.4	85.7	50.8	14.3	9.5	31.8	25.4	25.4
WH-78XHD*	66.954	16.330	2,722	15.1	9.4	85.7	50.8	14.3	9.5	31.8	25.4	25.4
WR-82XHD	78.105	22,861	3,810	12.8	12.6	95.3	60.3	19.1	9.5	38.1	28.6	31.8
WH-82XHD	78.105	25,855	4,309	12.8	12.6	95.3	60.3	19.1	9.5	38.1	28.6	31.8
WR-124XHD	103.200	38,556	6,441	9.8	21.7	123.8	76.2	25.4	12.7	50.8	38.1	41.3
WH-124XHD	103.200	55,339	9,253	9.8	21.7	123.8	76.2	25.4	12.7	50.8	38.1	41.3
WR-106XHD	153.670	38,556	6,441	6.6	17.6	123.8	76.2	25.4	12.7	50.8	38.1	44.5
WH-106XHD	153.670	55,339	9,253	6.6	17.6	123.8	76.2	25.4	12.7	50.8	38.1	44.5
WR-132XHD	153.670	54,432	9,072	6.6	22.8	171.5	118.3	25.4	15.9	50.8	69.9	44.5
WH-132XHD	153.670	55,339	9,253	6.6	22.8	171.5	118.3	25.4	15.9	50.8	69.9	44.5

*Fits in 4" channel

C TYPE EXTRA HEAVY DUTY CHAIN

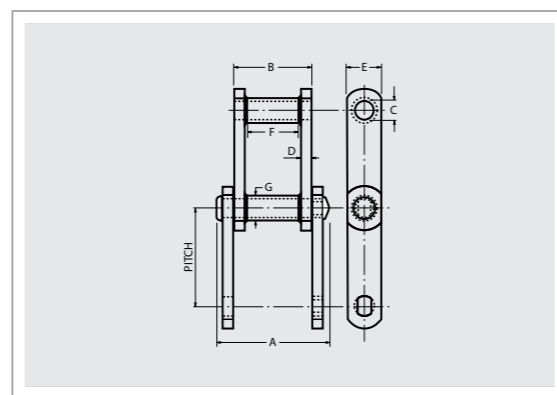
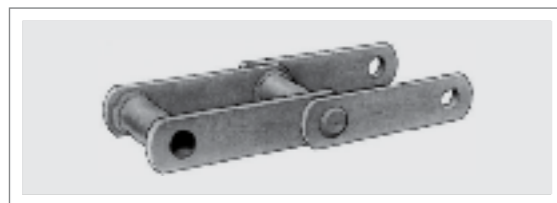

Chain Number	Pitch	Ultimate Strength	Allowable Working Load	Links	Average Weight	Approx. Overall Width	Length of Bearing	Rivet Dia.	Side Bar Thickness	Side Bar Height	Approx. Tooth Face at Pitch Line	Outside Barrel Dia.
						A	B	C	D	E	F	G
						mm						
WRC82XHD	78.105	25,855	4,309	12.8	12.4	95.3	60.3	19.1	9.5	38.1	28.6	31.8
WHC82XHD	78.105	25,855	4,309	12.8	12.4	95.3	60.3	19.1	9.5	38.1	28.6	31.8
WRC124XHD	103.200	38,556	6,441	9.8	21.7	123.8	76.2	25.4	12.7	50.8	38.1	41.3
WHC124XHD	103.200	55,339	9,253	9.8	21.7	123.8	76.2	25.4	12.7	50.8	38.1	41.3
WRC110XHD	153.670	38,556	6,441	6.6	17.6	123.8	76.2	25.4	12.7	50.8	38.1	44.5
WHC110XHD	153.670	55,339	9,253	6.6	17.6	123.8	76.2	25.4	12.7	50.8	38.1	44.5
WRC132XHD	153.670	54,432	9,072	6.6	22.8	171.5	118.3	25.4	15.9	50.8	69.9	44.5
WHC132XHD	153.670	55,339	9,253	6.6	22.8	171.5	118.3	25.4	15.9	50.8	69.9	44.5

The following pages detail some of the standard mill chain attachments that we manufacture. CAN-AM CHAINS has also manufactured thousands of special attachments in conjunction with our customers, to solve specific conveying problems. In many cases these design changes have resulted in a substantial increase in the chain's overall service life and in some cases as much as a three (3) times increase.

We are problem solvers. Challenge us to perform for you!

K1 ATTACHMENTS AND A1 ATTACHMENTS (IF ONE SIDE)

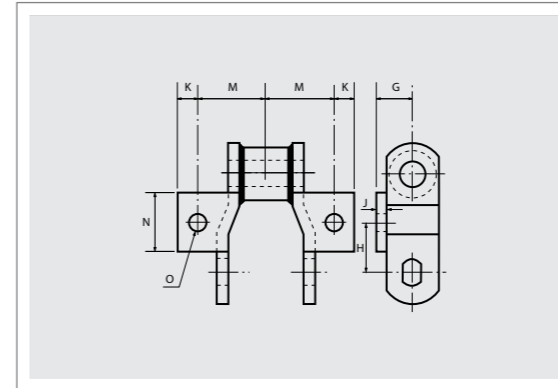

Chain Number	G	H	J	K	M	N	Bolt Size O
	mm						
WR-78	22.23	31.75	6.35	12.70	50.80	31.75	9.53
WR-78HD(X)	22.23	31.75	6.35	12.70	50.80	31.75	9.53
WR-82	22.23	38.10	6.35	15.88	60.33	44.45	9.53
WR-82XHD	28.58	38.10	9.53	15.88	60.33	44.45	9.53
WR-124	28.58	50.80	9.53	15.88	66.68	44.45	9.53
WR-124XHD	38.10	50.80	12.70	19.05	66.68	44.45	12.70
WR-111	31.75	53.98	9.53	15.88	79.38	44.45	9.53
WR-132	38.10	76.20	12.70	22.23	95.25	50.80	12.70
WR-132HD(X)	38.10	76.20	12.70	22.23	95.25	50.80	12.70

K2 ATTACHMENTS AND A2 ATTACHMENTS (IF ONE SIDE)

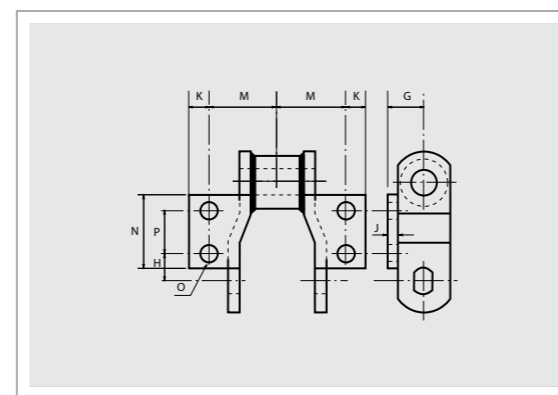

Chain Number	G	H	J	K	M	N	P	Bolt Size O
	mm							
WR-78	22.23	20.64	6.35	12.70	50.80	53.98	28.58	9.53
WR-78HD(X)	22.23	20.64	6.35	12.70	50.80	53.98	28.58	9.53
WR-82	22.23	12.70	6.35	15.88	53.98	57.15	31.75	9.53
WR-82XHD	28.58	12.70	9.53	15.88	60.33	57.15	31.75	9.53
WR-124	28.58	22.23	9.53	15.88	66.68	76.20	49.21	9.53
WR-124XHD	38.10	22.23	12.70	19.05	66.68	101.60	49.21	12.70
WR-111	31.75	25.40	9.53	19.05	79.38	101.60	58.74	9.53
WR-132	38.10	41.28	12.70	19.05	95.25	107.95	69.85	12.70
WR-132HD(X)	38.10	41.28	12.70	22.23	95.25	107.95	69.85	12.70
WR-150	44.45	41.28	12.70	22.23	95.25	107.95	69.85	12.70

R2 ATTACHMENTS

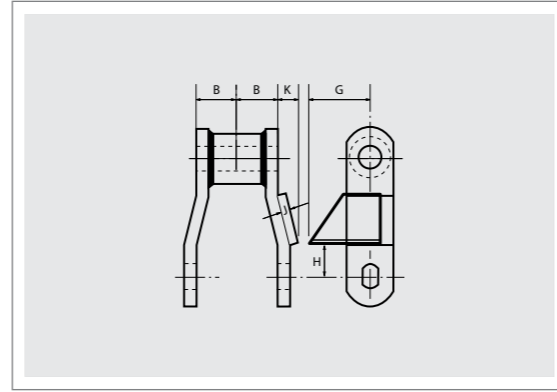

Chain Number	B	G	H	J	K	Average Weight Kg/Mtr
	mm					
WR-78	25.40	39.69	25.40	6.35	12.70	6.55
WR-78HD(X)	28.58	39.69	25.40	9.53	15.88	11.16
WR-82	28.58	44.45	20.64	6.35	12.70	8.93

RR-1 Attachments are similar except travel is narrow end forward. (Point direction is reversed.)

RR-2 ATTACHMENTS

RR Attachments available on all chains

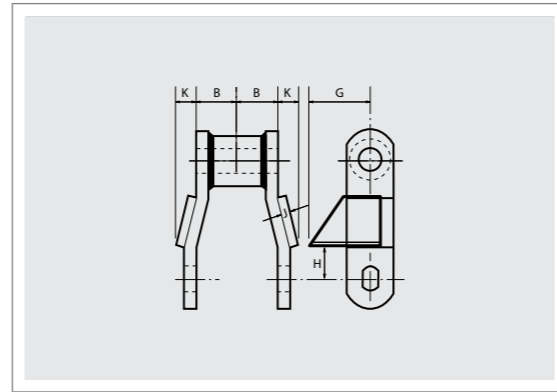

Chain Number	B	G	H	J	K	Average Weight Kg/Mtr
	mm					
WR-78	25.40	39.69	25.40	6.35	12.70	7.14
WR-78HD(X)	28.58	39.69	25.40	9.53	15.88	11.91
WR-82	28.58	44.45	20.64	6.35	12.70	9.67
WR-82XHD	30.16	52.39	20.64	9.53	19.05	12.65
WR-124	34.93	47.63	38.10	9.53	19.05	13.84
WR-132	55.96	63.50	38.10	12.70	22.23	23.81

RR-1 Attachments are similar except travel is narrow end forward. (Point direction is reversed.)

S1 ATTACHMENTS

- Weld on type supplied unless integral is specified (Quoted)
- WRC specifications as stated

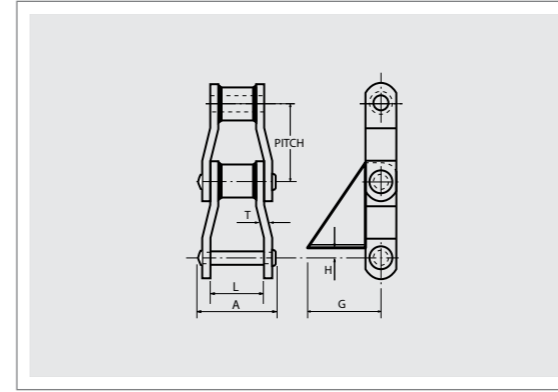

Chain Number	A	G	H	L	T	Average Weight Kg/Mtr
	mm					
WR-124	107.95	95.25	25.40	92.08	9.53	25.89
WR-111	122.24	101.60	25.40	106.36	9.53	27.23
WR-106	107.95	95.25	25.40	92.08	9.53	23.96
WR-124XHD	123.83	95.25	32.54	104.78	12.70	38.69
WR-132	158.75	127.00	32.54	134.14	12.70	26.79
WR-150	158.75	139.70	32.54	134.14	12.70	29.76

F4 ATTACHMENTS

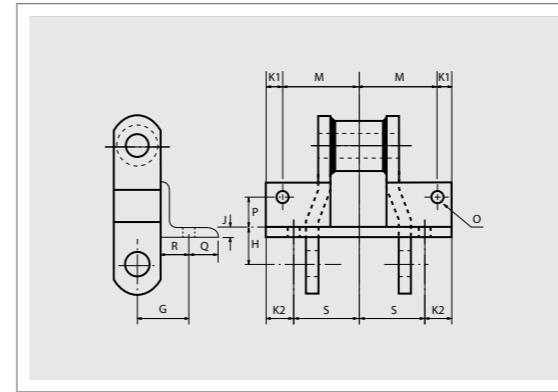

Chain Number	G	H	J	K1	K2	M	P	Q	R	S	Average Weight Kg/Mtr	Bolt Size O mm
	mm											
WR-78	44.45	25.40	6.35	12.70	22.23	57.15	23.81	15.88	28.58	47.63	12.35	9.53
WR-78XHD	44.45	25.40	6.35	12.70	22.23	57.15	23.81	15.88	28.58	47.63	14.73	9.53
WR-82	46.04	31.75	6.35	11.11	22.23	63.50	28.58	20.64	30.16	52.39	13.24	9.53
WR-82XHD	52.39	31.75	9.53	12.70	26.99	63.50	28.58	26.99	30.16	52.39	18.60	9.53
WR-124	52.39	29.37	9.53	12.70	26.99	66.68	26.99	26.99	33.34	52.39	17.26	9.53

H1 ATTACHMENTS

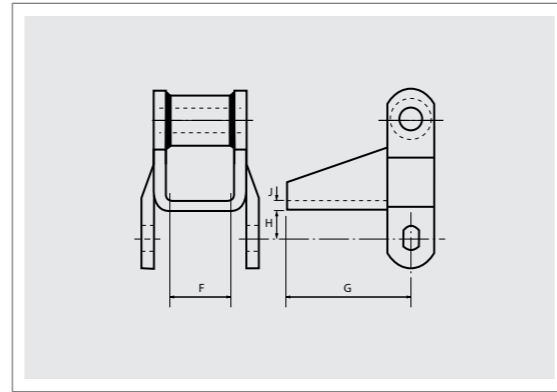

Chain Number	F	G	H	J	Average Weight Kg/Mtr
	mm				
WR-78	38.10	92.08	12.70	4.76	9.82
WR-78XHD	38.10	92.08	12.70	4.76	14.14
WR-82	44.45	92.08	15.88	4.76	13.24
WR-82XHD	44.45	98.43	15.88	4.76	18.01

Note: H1 Also fits 8DX

H2 ATTACHMENTS

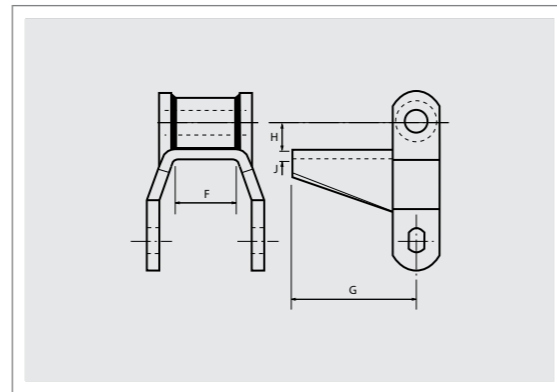

Chain Number	F	G	H	J	Average Weight Kg/Mtr
	mm				
WR-78	38.10	92.08	12.70	4.76	9.82
WR-78XHD	38.10	92.08	12.70	4.76	14.14
WR-82	44.45	92.08	15.88	4.76	13.24
WR-82XHD	44.45	98.43	15.88	4.76	18.01

RF2 ATTACHMENTS

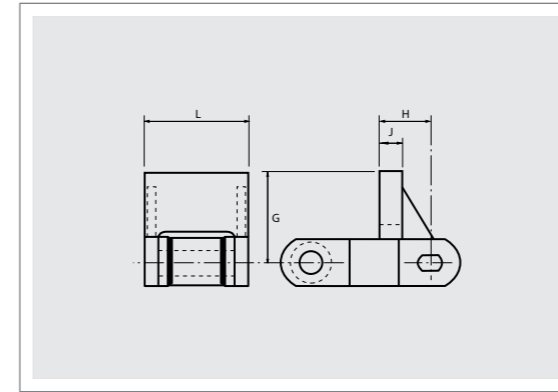

Chain Number	G	H	J	L	Average Weight Kg/Mtr
	mm				
WR-78	68.26	38.10	6.35	76.20	11.46
WR-78HD(X)	68.26	38.10	9.53	76.20	15.92
WR-82XHD	69.85	54.37	9.53	82.55	18.30
WR-124	82.55	50.80	12.70	107.95	23.51
WR-111	82.55	53.98	12.70	196.85	21.58
WR-132	88.90	76.20	19.05	228.60	42.41

Specifications for C Style Chain same as above
Specify L and G Dimension when ordering.

Also available for wide end forward operation.

RF12 ATTACHMENTS

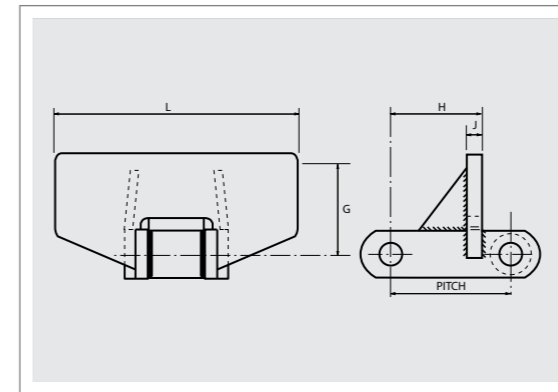

Chain Number	G	H	J	L	Average Weight Kg/Mtr
	mm				
WR-78	68.26	38.10	6.35	76.20	11.46
WR-78HD(X)	68.26	38.10	9.53	76.20	15.92
WR-82XHD	69.85	54.37	9.53	82.55	18.30
WR-124	82.55	50.80	12.70	107.95	23.51
WR-111	82.55	53.98	12.70	196.85	21.58
WR-132	88.90	76.20	19.05	228.60	42.41

Specifications for C Style Chain same as above
Specify L and G Dimension when ordering.

Also available for wide end forward operation.

A22 ATTACHMENTS

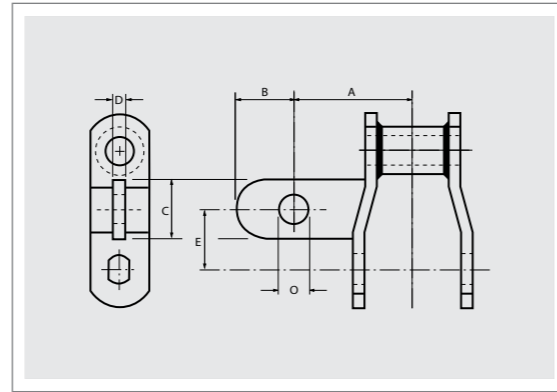

Chain Number	A	B	C	D	E	O
	mm					
WR-78	50.80	15.88	31.75	6.35	31.75	11.11
WR-124	76.20	22.23	44.45	9.53	50.80	14.29
WR-111	88.90	22.23	44.45	9.53	60.33	14.29
WR-106	69.85	22.23	44.45	9.53	76.20	14.29
WR-132	107.95	25.40	44.45	12.70	76.20	20.64
WR-132XHD	107.95	25.40	50.80	15.88	76.20	20.64

Specify left or right hand when ordering.

SPECIAL SLOTTED A22 FOR WAFERIZER CHAINS

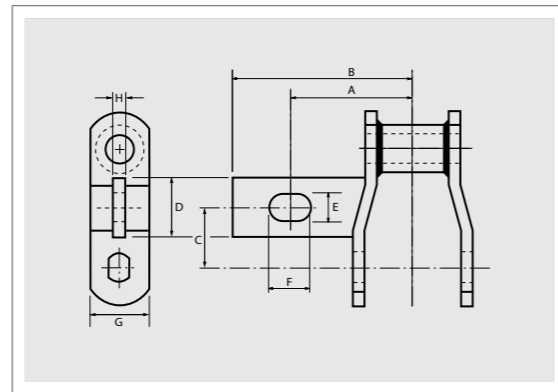

Chain Number	A	B	C	D	E	F	G	H
	mm							
WR-124	101.60	150.81	44.45	50.80	20.64	38.10	38.10	12.70
WR-124XHD	104.78	153.99	44.45	50.80	20.64	38.10	50.80	12.70
WR-106	101.60	150.81	76.20	50.80	20.64	38.10	38.10	12.70
WR-106XHD	104.78	153.99	76.20	76.20	20.64	38.10	50.80	12.70
WR-132	114.30	158.75	76.20	50.80	20.64	38.10	50.80	12.70
WR-132XHD	117.48	161.93	76.20	63.50	20.64	31.75	50.80	12.70
WR-144	101.60	150.81	76.20	50.80	20.64	38.10	44.45	12.70
WR-166	101.60	150.81	76.20	50.80	20.64	38.10	44.45	12.70

All items to the left are also available in "H" Series, fully heat treated, and/or plus "IBR" induction hardened options.

CAN-AM SIDE-LIFT LOG CHAINS

NOTE: Chains ordered separately will have end link supplied loose

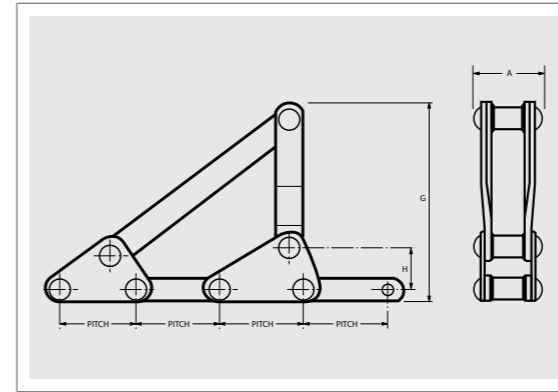

Chain Number	Average Pitch	Rivet Dia.	Overall Width	Height	H	Pitches per Assembly
			A	G		
mm						
WR-78	66.27	12.70	76.20	203.20-355.60	47.63	4-5
WR-82	78.11	14.29	82.55	254.00-355.60	47.63	5-6
WR-124	101.60	19.05	107.95	254.00-457.20	73.03	4-6
WR-124XHD	103.20	25.40	123.83	304.80-457.20	76.20	4-6
WR-106	152.40	19.05	107.95	304.80-508.00	95.25	4-6
WR-132	153.67	25.40	158.75	304.80-609.60	95.25	4-5
WR-132HD(X)	153.67	25.40	171.45	304.80-609.60	95.25	4-5
WR-150	153.67	25.40	158.75	304.80-609.60	101.60	4-5
WR-155	153.67	28.58	162.72	304.80-762.00	101.60	4-5
WR-157	153.67	28.58	171.45	304.80-762.00	101.60	4-5

CAN-AM UHMW FLIGHTS

Sleeves are constructed of UHMW and press fitted over steel tube or flat bar. CAN-AM UHMW flights act as the wear strip in the bottom of the conveyor.

Easily replaced sleeves save flat bar and chain wear and greatly reduce maintenance costs. Other features include reduced power consumption and noise reduction.

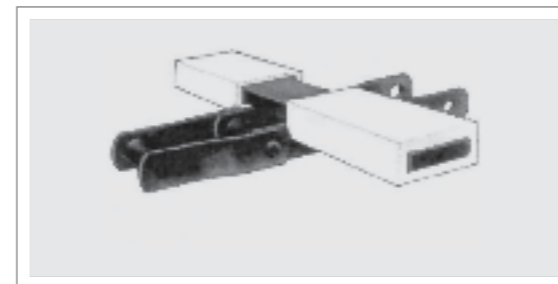

Flat Bar Style
 FB = 3 1/2" x 1"
 UHMW = 4 1/2" x 2" outside

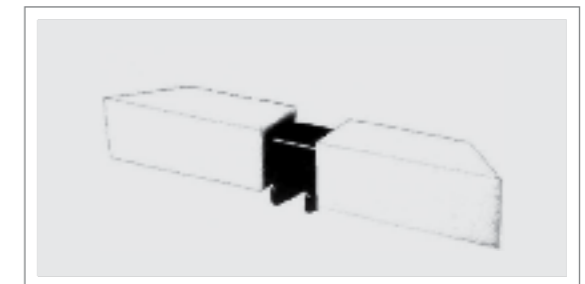

HSS Square Tube Style
 Tube = 3" x 3"
 UHMW = 4" x 4" outside

LOG CRADLE FOR SINGLE STRAND CHAIN

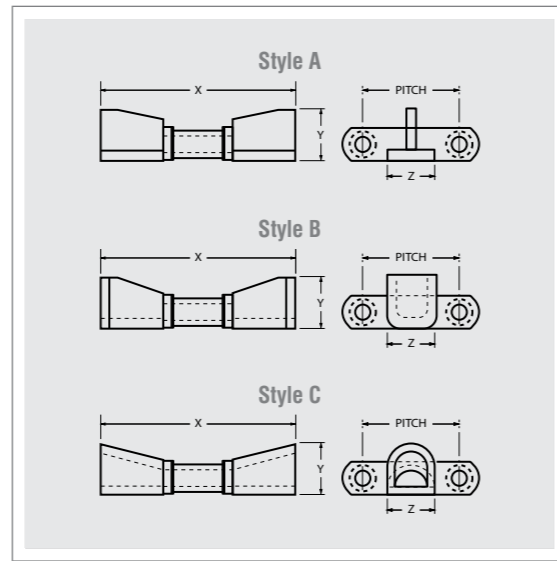
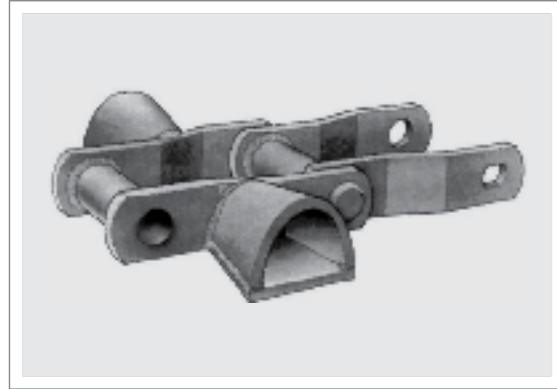

Chain Number	Pitch	Style A			Style B			Style C			Special Style C		
		X	Y	Z	X	Y	Z	X	Y	Z	X	Y	Z
WR-124	101.60	203.20	63.50	63.50	203.20	63.50	57.15	203.20	57.15	88.90	279.40	74.61	76.20
WR-111	120.90	215.90	57.15	44.45	215.90	76.20	57.15	215.90	57.15	88.90	279.40	74.61	76.20
WR-124XHD	102.87	215.90	76.20	63.50	215.90	76.20	63.50	215.90	76.20	76.20	279.40	95.25	76.20
WR-106	152.40	203.20	57.15	76.20	203.20	57.15	57.15	203.20	57.15	88.90	295.28	74.61	88.90
WR-132	153.67	279.40	76.20	76.20	279.40	76.20	82.55	279.40	76.20	88.90	330.20	88.90	88.90
WR-132XHD	153.67	285.75	76.20	76.20	285.75	76.20	76.20	295.28	76.20	88.90	346.08	82.55	88.90

Note: Style "A" cradles could pose conveying problems – discuss with factory.

SPECIAL SLASHER ATTACHMENTS*

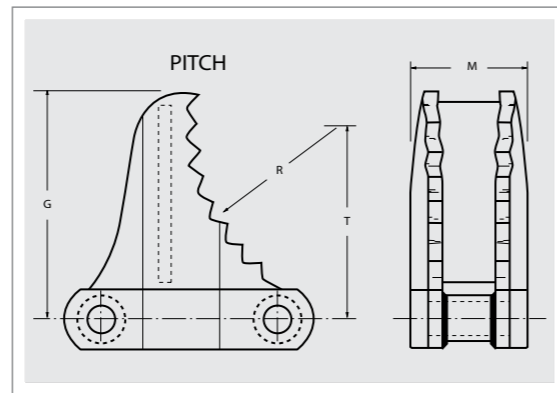
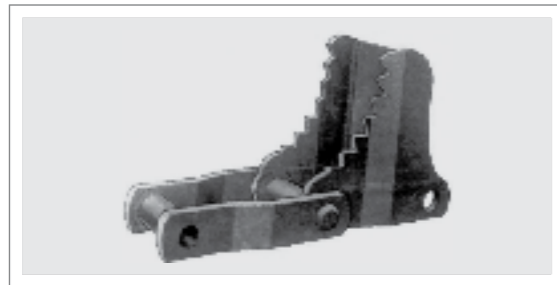

Chain Number	G	R	T	M
	mm			
WR-124	185.74	304.80	177.80	101.60
WR-124XHD	185.74	304.80	177.80	107.95
WR-106	209.55	152.40	171.45	98.43
WRC-110	209.55	152.40	171.45	98.43
WR-106XHD	228.60	161.93	177.80	103.58
WR-132	185.74	152.40	177.80	139.70
WRC-132	185.74	152.40	177.80	139.70

*Available integral to sidebar or welded on

CAN-AM WELDED STEEL UNIVERSAL TOP

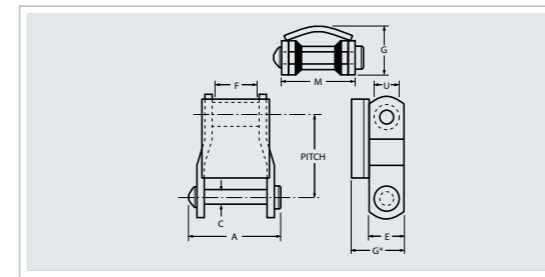
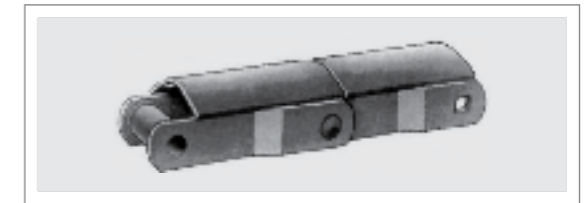

Chain Number	Chain Pitch	Links	Average Weight	A	C	E	F	G*	M	U
				mm						
WR-78 U	66.27	15.1	8.93	76.20	12.70	31.75	25.40	46.04	66.68	22.23
WR-78 XHDU	66.95	15.1	15.48	87.63	14.29	31.75	25.40	48.26	71.44	25.40
WR-82 U	78.11	12.8	11.91	88.90	14.29	31.75	28.58	50.80	76.20	25.40
WR-82 XHDU	78.11	12.8	20.09	101.60	19.05	38.10	28.58	60.33	84.14	31.75
WR-130/8U	101.60	9.8	7.14	76.20	12.70	31.75	25.40	46.04	66.68	22.23
WR-124 U	101.60	9.8	19.35	107.95	19.05	38.10	38.10	63.50	92.08	31.75
WR-124 XHDU	103.20	9.8	29.47	117.48	25.40	50.80	38.10	82.55	103.19	41.28

* Nominal Dimension

CAN-AM WELDED STEEL CHAIN WITH U.H.M.W. CAP

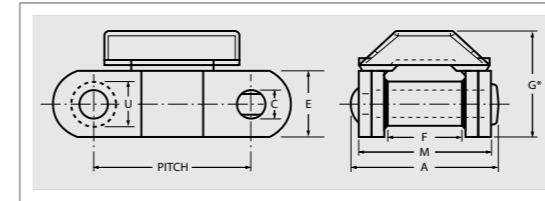
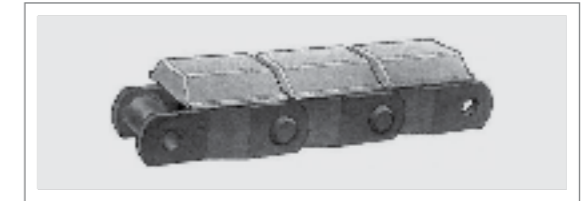

Chain Number	Chain Pitch	Links	Average Weight	A	C	E	F	G*	M	U
				mm						
WR-78 UP	66.27	15.1	8.04	76.20	12.70	31.75	25.40	49.21	66.68	22.23
81X UP	66.27	15.1	5.06	63.50	11.11	28.58	22.23	47.63	41.28	22.23

* Nominal Dimension

STEEL ROLL TOP CHAIN WITH NYLON ROLLERS

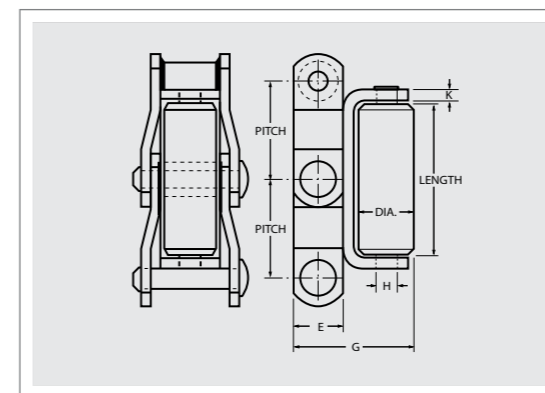

Chain Number	Chain Pitch	Links	Average Weight	Roller Length	Roller Dia.	Side Bar Width	Overall Height	Cradle Material	Roller Rivet Dia.
						E	G	K	H
WR-78RTN	66.27	15.1	11.68	101.60	31.75	31.75	79.38	6.35	12.70

Standard rolltop chain supplied with solid nylon roller. WRC 78 (combination chain) styles also available.

CAN-AM WELDED STEEL DRAG CHAINS

CAN-AM WELDED STEEL DRAG CHAINS provide efficient and economical service when used in chip and sawdust conveyors, and like applications. Features include original formed barrel design for complete rivet to barrel contact for maximum rivet wear, higher impact strength, weldability of attachments and option of heat treating and/or induction hardening specific parts.

Reverse barrel chain is available. Contact Factory.

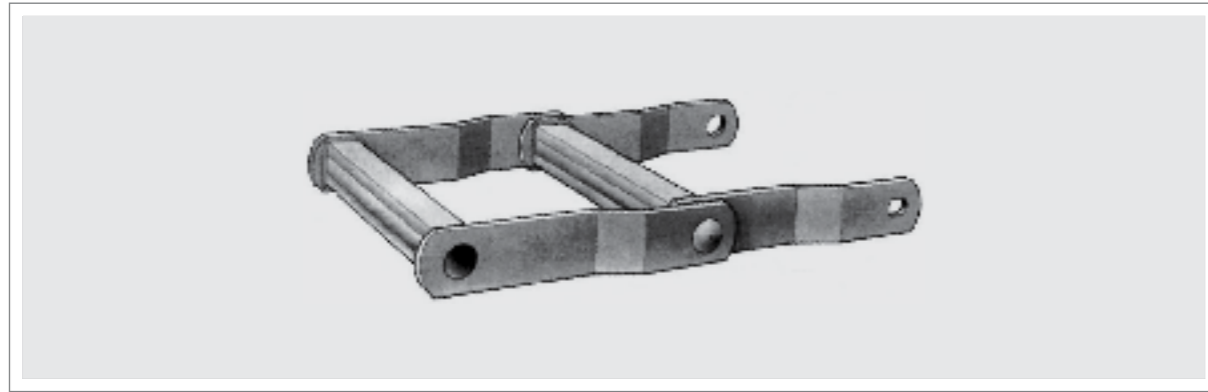
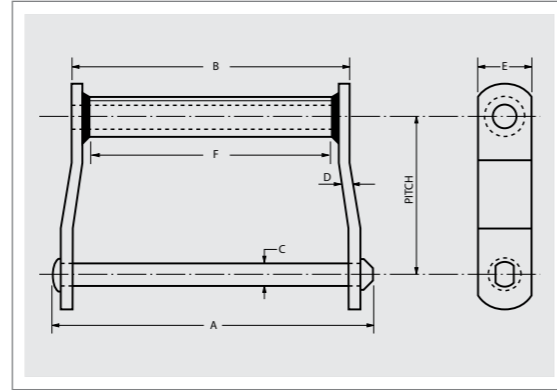

Chain Number	Pitch mm	Ultimate Strength Kg	Allowable Working Load	Links Pcs./Mtr	Average Weight Kg/Mtr	Overall Width	Length of Bearing	Rivet Dia.	Side Bar Thickness	Side Bar Height	Maximum Sprocket Face
						A	B	C	D	E	F
WD-102	127.000	23,134	4,627	7.87	17.9	235.0	196.9	19.1	9.5	38.1	161.9
WD-104	152.400	23,134	4,627	6.56	12.1	171.5	136.5	19.1	9.5	38.1	104.8
WD-110	152.400	23,134	4,627	6.56	17.9	298.5	260.4	19.1	9.5	38.1	228.6
WD-112	203.200	23,134	4,627	4.92	14.1	298.5	260.4	19.1	9.5	38.1	228.6
WD-116	203.200	23,134	4,627	4.92	20.5	393.7	358.8	19.1	9.5	44.5	330.2
WD-118	203.200	31,752	6,350	4.92	27.8	422.3	377.8	22.2	12.7	50.8	336.6
WD-120	152.400	31,752	6,350	6.56	27.4	304.8	260.4	22.2	12.7	50.8	222.3
WD-122	203.200	31,752	6,350	4.92	22.8	304.8	260.4	22.2	12.7	50.8	222.3
WD-480	203.200	31,752	6,350	4.92	25.4	368.3	323.9	22.2	12.7	50.8	279.4

*Also available in 1" Ø pin

CAN-AM (XHD) HEAVY DUTY DRAG CHAINS

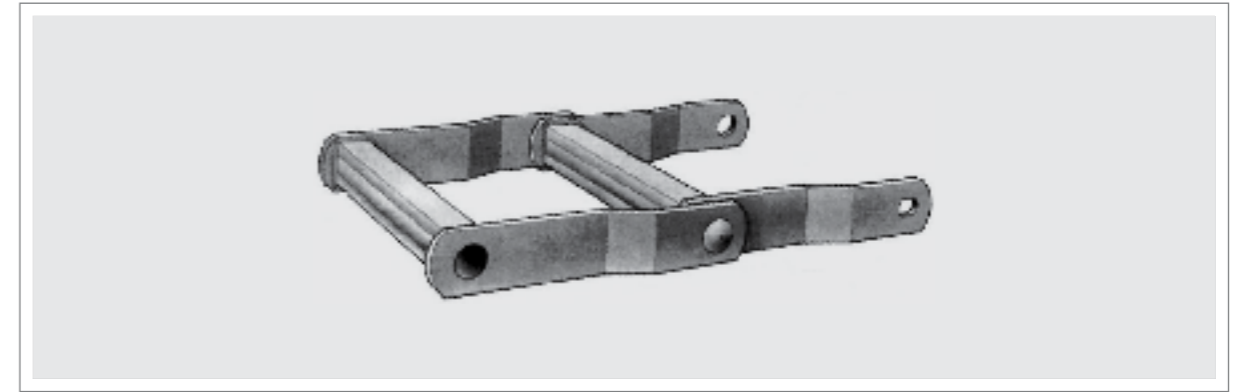
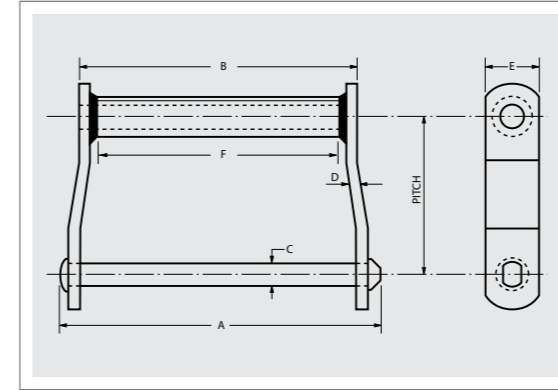

Chain Number	Pitch mm	Ultimate Strength Kg	Allowable Working Load	Links Pcs./Mtr	Average Weight Kg/Mtr	Overall Width	Length of Bearing	Rivet Dia.	Side Bar Thickness	Side Bar Height	Maximum Sprocket Face
						A	B	C	D	E	F
WD-120XHD	152.400	55,339	11,068	6.56	33.5	323.9	266.7	25.4	15.9	50.8	222.3
WD-118XHD	203.200	55,339	11,068	4.92	33.5	441.3	384.2	25.4	15.9	50.8	279.4
WD-122XHD	203.200	55,339	11,068	4.92	29.0	323.9	266.7	25.4	15.9	50.8	222.3
WD-480XHD	203.200	55,339	11,068	4.92	31.3	387.4	330.2	25.4	15.9	50.8	279.4

SUPER HOG CHAIN

CAN-AM "SUPER HOG" DRAG CHAIN features a formed, heavy wall seamless tube barrel. This rugged barrel supports a through and induction hardened 1" steel rivet. The "Super Hog" design eliminates crushed/peeled barrels and reduces wear due to racking. When the going gets tough...use CAN-AM "Super Hog" in log hauls, chip conveyors & heavy duty hog fuel handling application.

Standard "SUPER HOG" chains feature fully through hardened then induction hardened rivets available with heat-treated sidebars (WDRS) or heat-treated sidebar and barrels (WDH).

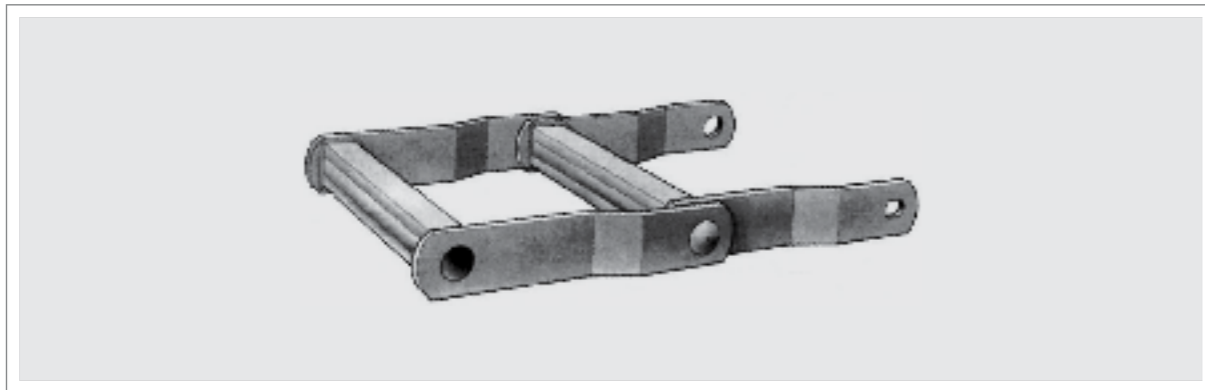
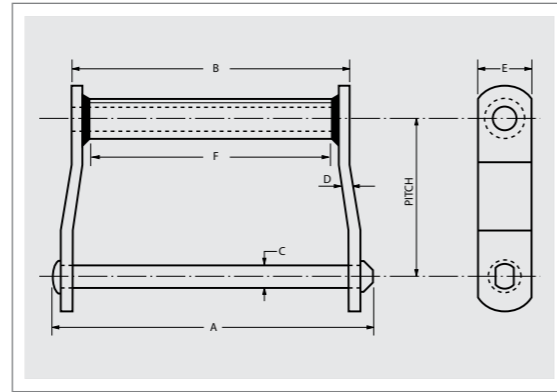

**HEAVY BARRELS RESIST CRUSHING • CAN BE RUN FASTER • LONGER LIFE • LESS DOWNTIME
• SNUG FITTING RIVETS MINIMIZE RACKING • WILL MOVE HEAVIER LOADS**

Chain Number	Pitch	Ultimate Strength	Allowable Working Load	S.H.* Links	Average Weight	Overall Width	Length of Bearing	Rivet Dia.	Side Bar Thickness	Side Bar Height	Maximum Sprocket Face
						A	B	C	D	E	F
						mm					
WDRS118-SH	203.200	38,783	7,757	4.92	32.7	422.3	377.8	25.4	12.7	50.8	336.6
WDRS118-XHDSH	203.200	55,339	11,068	4.92	36.5	441.3	377.8	25.4	15.9	50.8	336.6
WDRS120-SH	152.400	38,783	7,757	6.56	32.7	304.8	260.4	25.4	12.7	50.8	222.3
WDRS120-XHDSH	152.400	55,339	11,068	6.56	35.7	323.9	260.4	25.4	15.9	50.8	222.3
WDRS122-SH	203.200	38,783	7,757	4.92	26.0	304.8	260.4	25.4	12.7	50.8	222.3
WDRS122-XHDSH	203.200	55,339	11,068	4.92	29.8	323.9	260.4	25.4	15.9	50.8	222.3
WDRS480-SH	203.200	38,783	7,757	4.92	32.0	368.3	323.9	25.4	12.7	50.8	279.4
WDRS480-XHDSH	203.200	55,339	11,068	4.92	34.2	387.4	330.2	25.4	15.9	50.8	279.4

*SH = Super Hog

WORK HOG CHAINS

CAN-AM "WHOLE HOG" DRAG CHAIN has the same rugged characteristics as the "Super Hog". The main difference...the barrel is extra heavy, round, but packed with the same oversize, greased rivet. This chain is for "Big" logs and two way operations. Use "Whole Hog" for applications so brutal that only a real "tough" chain will do the job. CAN-AM chain...built to take it!

Standard "WHOLE HOG" chains feature fully through hardened then induction hardened rivets and through hardened side bars.

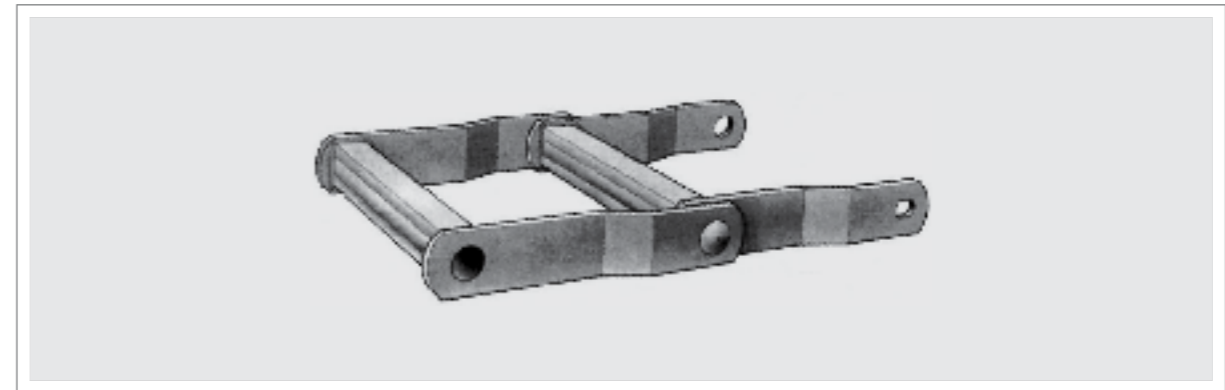
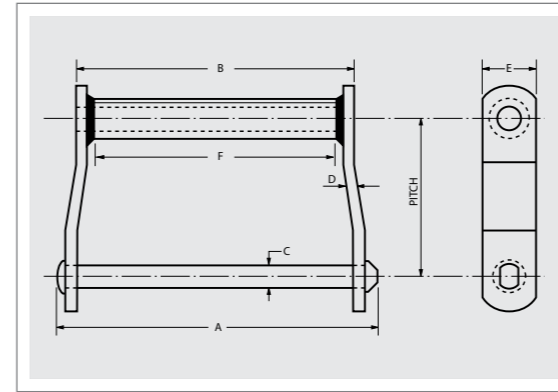

**HEAVY BARRELS RESIST CRUSHING • CAN BE RUN FASTER • LONGER LIFE • LESS DOWNTIME
• SNUG FITTING RIVETS MINIMIZE RACKING • WILL MOVE HEAVIER LOADS**

Chain Number	Pitch	Ultimate Strength	Allowable Working Load	W.H.* Links	Average Weight	Overall Width	Length of Bearing	Rivet Dia.	Side Bar Thickness	Side Bar Height	Maximum Sprocket Face
						A	B	C	D	E	F
						mm					
WDRS118-WH	203.200	38,783	7,757	4.92	37.9	422.3	377.8	25.4	12.7	50.8	336.6
WDRS118-XHDWH	203.200	55,339	11,068	4.92	41.7	441.3	377.8	25.4	15.9	50.8	336.6
WDRS120-WH	152.400	38,783	7,757	6.56	35.7	304.8	260.4	25.4	12.7	50.8	222.3
WDRS120-XHDWH	152.400	55,339	11,068	6.56	40.2	323.9	260.4	25.4	15.9	50.8	222.3
WDRS122-WH	203.200	38,783	7,757	4.92	29.8	304.8	260.4	25.4	12.7	50.8	222.3
WDRS122-XHDWH	203.200	55,339	11,068	4.92	32.7	323.9	260.4	25.4	15.9	50.8	222.3
WDRS480-WH	203.200	38,783	7,757	4.92	33.5	368.3	323.9	25.4	12.7	50.8	279.4
WDRS480-XHDWH	203.200	55,339	11,068	4.92	37.2	387.4	330.2	25.4	15.9	50.8	279.4

*WH = Whole Hog

WING ATTACHMENTS

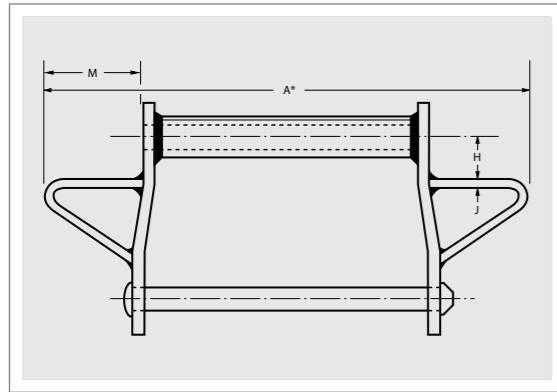
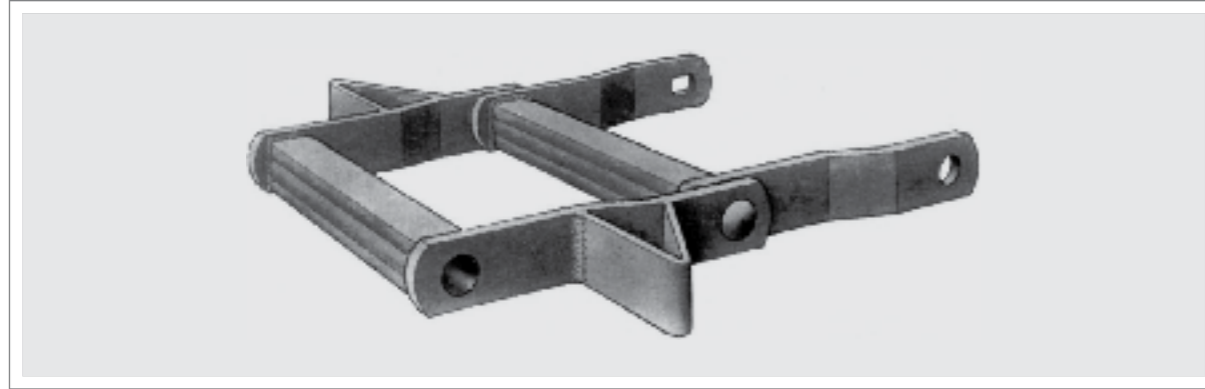

Chain Number	A*	H	J	M
	mm			
WD 102	368.3	38.1	9.5	82.6
WD 104	304.8	57.2	9.5	85.7
WD 110	431.8	57.2	9.5	85.7
WD 112	431.8	57.2	9.5	85.7
WD 113	431.8	57.2	9.5	85.7
WD 116	558.8	63.5	9.5	100.0
WD 118	558.8	63.5	12.7	90.5
WD 120	431.8	63.5	12.7	85.7
WD 122	431.8	63.5	12.7	85.7
WD 480	558.8	63.5	12.7	117.5
WD 120XHD	438.2	63.5	12.7	82.6
WD 118XHD	565.2	63.5	12.7	87.3
WD 480XHD	565.2	63.5	12.7	114.3

*Please specify measurement

ATTACHMENTS C-1/2", C-1, C-3, C-4

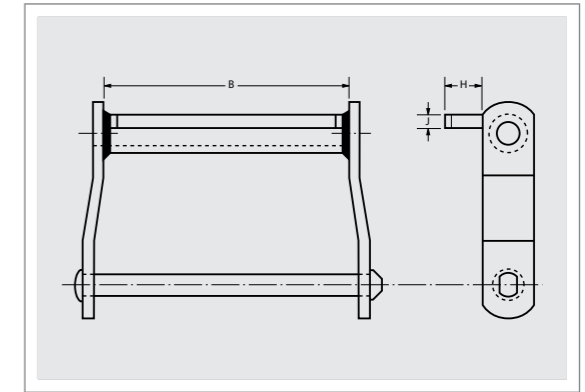
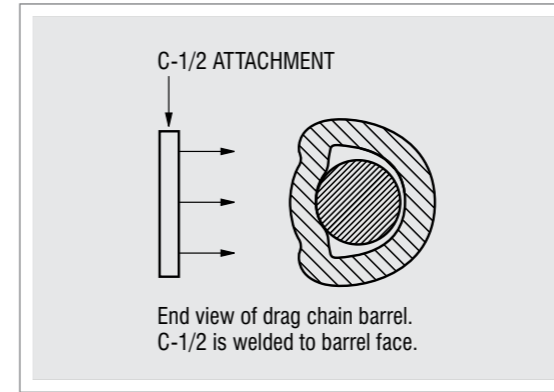

Chain Number	C-1/2*			C-1			C-3			C-4		
	B	J	H	B	J	H	B	J	H	B	J	H
	mm											
WD 102	171.5	9.5	38.1	171.5	9.5	38.1	171.5	9.5	44.5	171.5	9.5	76.2
WD 104	114.3	9.5	38.1	114.3	9.5	38.1	114.3	9.5	44.5	114.3	9.5	76.2
WD 110	235.0	9.5	38.1	235.0	9.5	38.1	235.0	9.5	44.5	235.0	9.5	76.2
WD 112	235.0	9.5	38.1	235.0	9.5	38.1	235.0	9.5	44.5	235.0	9.5	76.2
WD 113	228.6	12.7	38.1	228.6	12.7	44.5	228.6	12.7	44.5	228.6	12.7	101.6
WD 116	330.2	9.5	44.5	330.2	9.5	44.5	330.2	9.5	44.5	330.2	9.5	101.6
WD 118	342.9	12.7	50.8	342.9	12.7	44.5	342.9	12.7	50.8	342.9	12.7	101.6
WD 120	228.6	12.7	50.8	228.6	12.7	44.5	228.6	12.7	50.8	228.6	12.7	101.6
WD 122	228.6	12.7	50.8	228.6	12.7	44.5	228.6	12.7	50.8	228.6	12.7	101.6
WD 480	292.1	12.7	50.8	292.1	12.7	44.5	292.1	12.7	50.8	292.1	12.7	101.6

*Note: C-1/2 attachments are welded on front of barrel, whereas C-1, C-3, C-4 attachments are welded on top of barrel. C-1/2 attachments do not extend above sidebar height.

MALLEABLE CHAIN

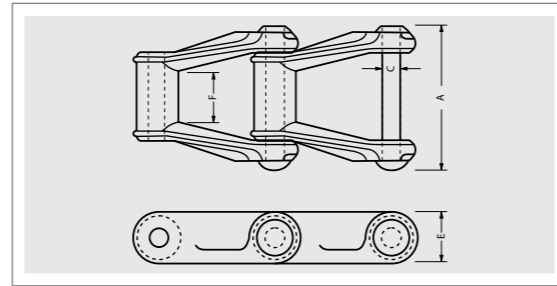

Chain Number	Pitch mm	Ultimate Strength Kg	Links Pcs./Mtr	Average Weight Kg/Mtr	Overall Width	Rivet Dia.	Side Bar Height	Maximum Sprocket Face
					A	C	E	F
H-78	66.269	9,163	15.09	6.3	85.7	12.7	28.6	25.4
H-82	78.105	9,979	12.80	8.2	103.2	14.3	31.8	28.6

STEEL AND MALLEABLE COMBINATION CHAIN

Combination chains consist of heat treated pearlitic malleable iron centre links with carbon steel side bars.

*Available in riveted or pin & cotter construction. SS pins & cotters also available from stock.

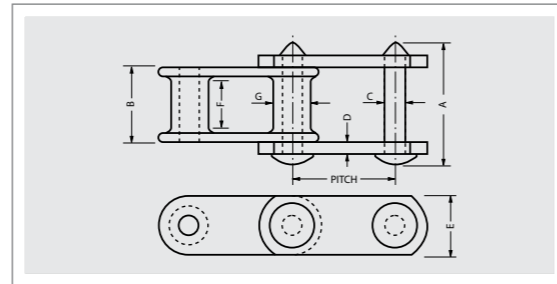

Chain Number	Pitch mm	Ultimate Strength Kg	Links Pcs./Mtr	Average Weight Kg/Mtr	Overall Width	Length of Bearing	Rivet Dia.	Side Bar Thickness	Side Bar Height	Maximum Sprocket Face	Barel Dia.
					A	B	C	D	E	F	G
C 55*	41.402	4,082	24.28	3.0	46.1	31.0	9.5	5.6	18.3	19.1	18.3
C 77*	58.623	4,990	17.06	3.4	53.2	31.8	11.1	4.8	22.2	17.5	18.3
C 188	66.269	6,350	15.09	5.2	66.7	39.7	12.7	6.4	28.6	22.2	22.2
C 131	78.105	10,886	12.80	10.0	92.1	50.8	15.9	9.5	38.1	28.6	31.0
C 102B	101.600	10,886	9.84	9.5	115.9	70.6	15.9	9.5	38.1	38.1	25.4

DOUBLE FLEX CHAINS

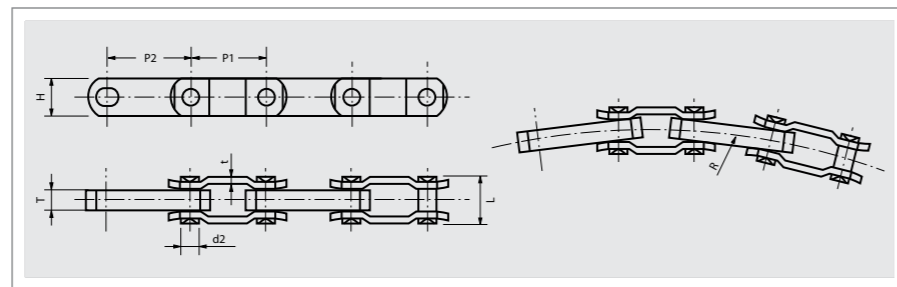

Chain Number	Pitch		Inner Plate Thickness T	Pin Dimension		Plate Dimension		Side Bow Radius R min Degrees	Ultimate Tensile Strength Q min Kg	Weight Kg/Mtr
	P1	P2		d2 max mm	L max	H max	t			
3500	63,5	76,2	15,87	14,22	36,51	31,75	6,35	20	38,935	5,2

MALLEABLE TRANSFER CHAIN

Rooftop and Camelback are widely used in the lumber industry on transfer decks, where the load is carried transversely on two or more strands of chain and entry or discharge is endways. Maximum advisable speed is 100 feet per minute.

ROOF TOP H-78A, H-130

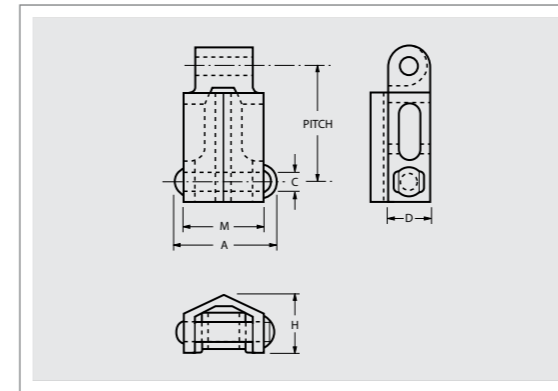

CAMELBACK H-78B, H-138

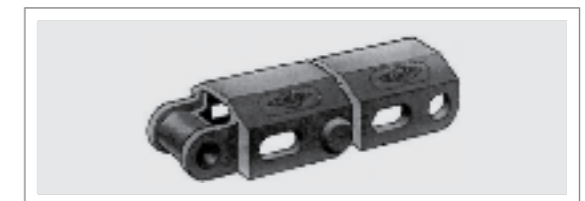
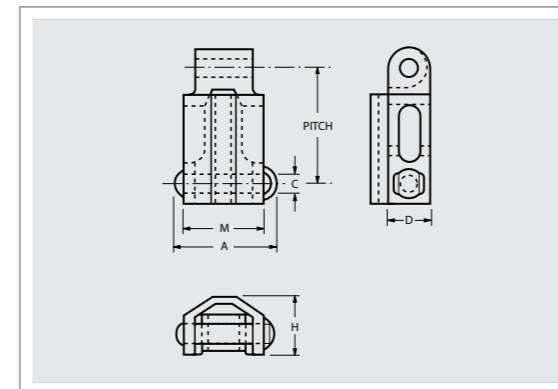

COMBINATION: ROOF TOP C-55A, CAMELBACK C-55B, UNITOP C-55D



Chain Number	Pitch mm	Ultimate Strength Kg	Links Pcs./Mtr	Average Weight Kg/Mtr	Overall Width	Roof Width	Rivet Dia.	Side Bar Height	Overall Height
					A	M	C	D	H
H-78A	66.269	7,258	15.09	8.3	82.6	69.9	12.7	27.0	42.9
H-78B	66.269	7,258	15.09	9.1	82.6	69.9	12.7	27.0	42.9
H-130	101.600	6,350	9.84	7.7	82.6	71.4	12.7	28.2	42.9
H-138	101.600	6,804	9.84	8.6	82.6	71.4	12.7	28.2	42.9
C55A, C55B, C55D	41.402	4,082	24.28	4.8	50.8	30.5	9.5	19.1	31.8

NOTE: Snap-on urethane caps available for non-marking applications.

POWER TRANSMISSION CHAINS

POWER TRANSMISSION CHAINS are widely used throughout the lumber industry in a broad range of conveying, transmission, and elevating applications. They are available in either offset or straight sidebar design. The majority of bushed roller chains are best suited for slow or moderate speed drive and conveyor applications since they are made to commercial standards for clearance, fits, and limits. Broaches on one end of the rivet

and flats on both ends of the bushing prevent these parts from rotating in the sidebar holes. These chains are widely used throughout the industry with our cast steel bullnose or other special attachments for use on trim tables. (See pages 35 and 36.)

OFFSET SIDEBAR STYLE

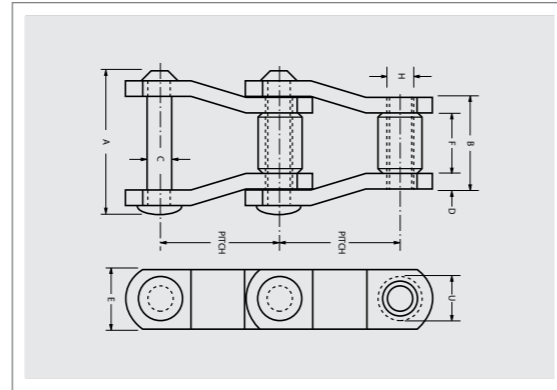

Chain Number	Chain Style	Pitch mm	Ultimate Strength Kg	Allowable Working Load Kg	Links Pcs./Mtr	Average Weight Kg/Mtr	Sidebars			Pins		Bushing		Roller		Length of Bearing mm		
							D	E	Material	C	A	Material	H	Material	U		F	Material
SO-578	0	66.269	8,618	998	15.09	4.0	4.0	25.4	CH	9.5	52.8	CH	14.3	CC	22.2	27.0	CC	36.5
MO-88	0	66.269	9,072	1,089	15.09	5.7	6.4	28.6	C	11.1	59.5	CH	15.9	CC	22.2	27.0	CC	41.3
LXS-882	0	66.269	13,154	1,270	15.09	5.8	6.4	28.6	CH	11.1	59.5	AH	15.9	AC	22.2	28.6	CH	176.2
MOH-578	0	66.269	8,618	998	15.09	4.0	5.6	25.4	CH	9.5	52.8	CH	14.3	CC	22.2	27.0	CH	36.1

STRAIGHT SIDEBAR STYLE

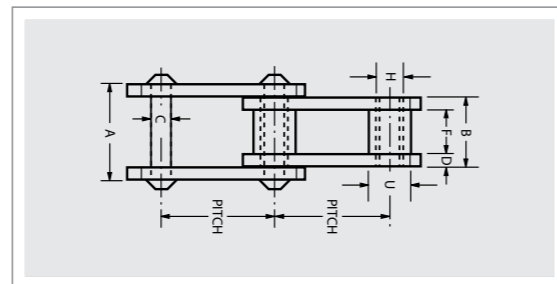
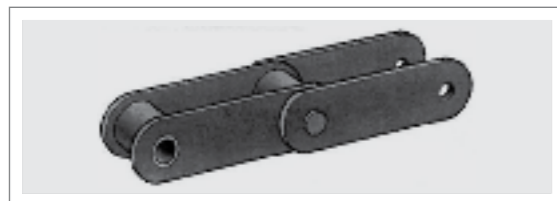

Chain Number	Chain Style	Pitch mm	Ultimate Strength Kg	Allowable Working Load Kg	Links Pcs./Mtr	Average Weight Kg/Mtr	Sidebars			Pins		Bushing		Roller		Length of Bearing mm			
							Block	Conn	Height	Material	C	A	Material	H	Material		U	F	Material
MS-88	S	66.269	11,794	1,134	15.09	5.7	6.4	6.4	28.6	C	11.1	59.5	CH	15.9	CC	22.2	27.0	CC	41.3
81-X	S	66.269	9,979	998	15.09	3.9	4.0	4.0	28.6	CH	11.1	47.2	AC	15.9	AC	23.0	27.0	CH	34.9
81-XH	S	66.269	18,960	2,268	15.09	5.8	7.9	5.6	31.8	CH	11.1	59.2	AC	15.9	AC	23.0	27.0	CH	42.9
81-XHS	S	66.269	18,960	2,268	15.09	6.3	7.9	7.9	32.9	CH	11.1	63.5	AC	15.9	AC	23.0	27.0	CH	42.9
SS-188	0	66.269	11,794	1,134	15.09	5.7	6.4	6.4	28.6	CH	11.1	59.5	AC	-	-	22.2	27.0	CC	41.3

See page 44 for "J" Bar sorter chains.

Zero = no roller.

Letter designation of material:

C: carbon steel

CC: carbon steel case hardened

AC: alloy steel case hardened

CH: carbon steel heat treated

AH: alloy steel heat treated

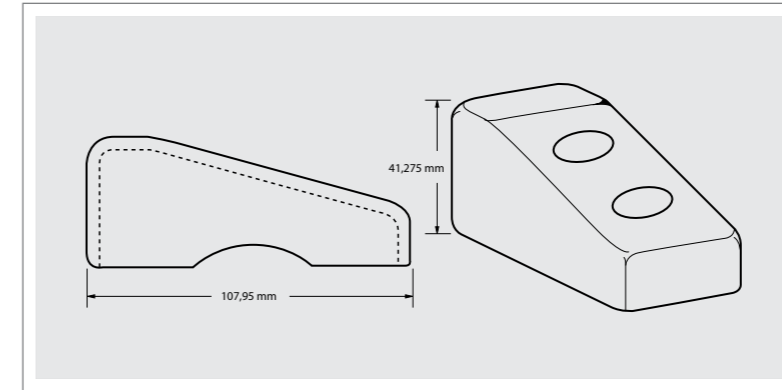

CAST STEEL TRIMMER LUGS

- Suitable for the following chains: SO-578, 81X, 81-XH, MS-88, MO-88, LXS-882
- Lugs available with self cleaning holes as shown in sketch

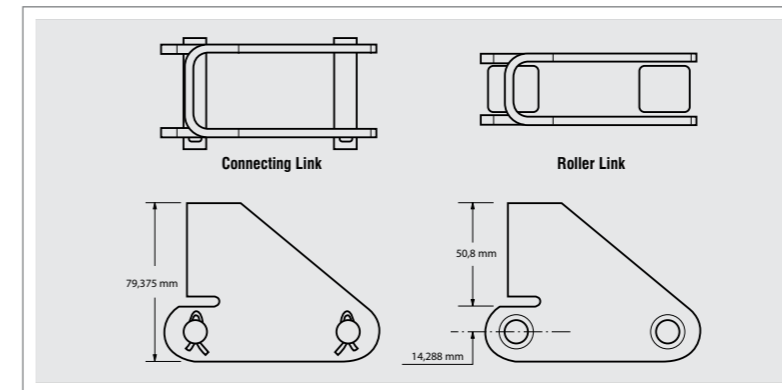

81-X PUSHER LUGS

- Strong integral pusher lug for many sawmill applications
- Available from stock as a connecting link or roller link

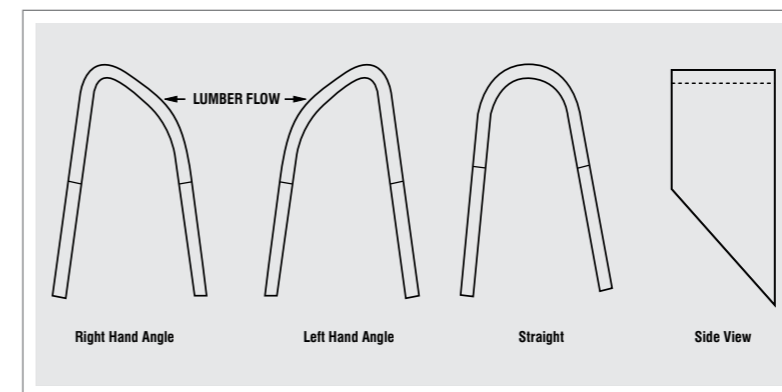

CAN-AM FABRICATED STEEL BULLNOSE ATTACHMENTS

Standard heights of 1 1/2" - 1 3/4" - 2" are available from stock. Manufactured for welded steel chain and trimmer chain.

TRIMMER UHMW ROLLER STYLE LUGS

Roller Style

- Suitable for all trimmer chains SO-578, 81X, 81-XH, MS88-MO88, LXS882, MOH578
- For maximum chain life LXS882 recommended
- Height and Outside Diameter can be manufactured to your specific requirements

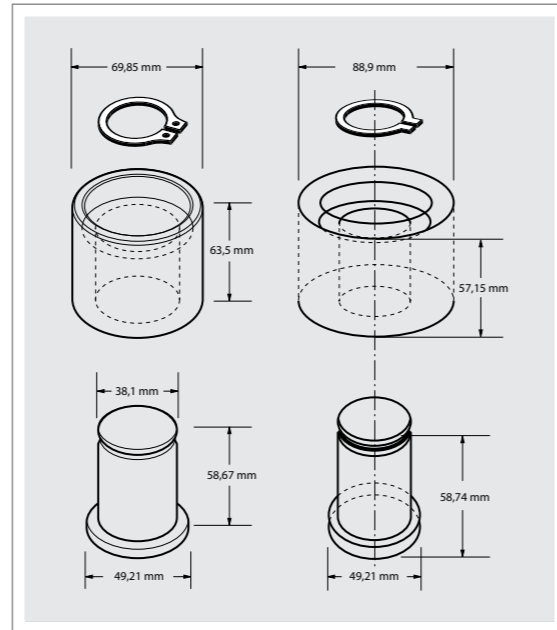

81-X ROOFTOP

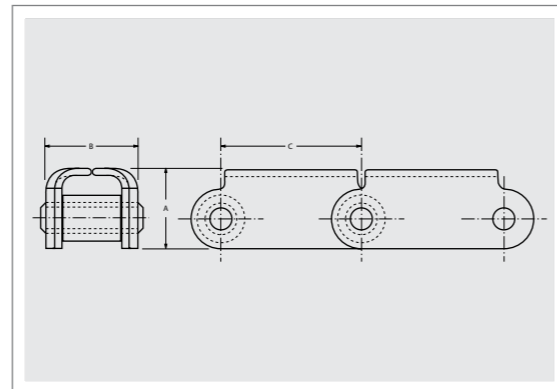

Chain Number	A	B	C
	mm		
81-X Rooftop	38,1	46,04	66,27

- All CAN-AM Mill Chain Rivets are through heat treated as standard
- All Super Hog and Whole Hog Chain Rivets 1" diameter and larger are supplied through and induction hardened as standard
- All Trimmer Chain Rivets are supplied Heat Treated as standard
- Other Induction Hardening & Heat Treating options are available on request, as are zinc plating and galvanizing

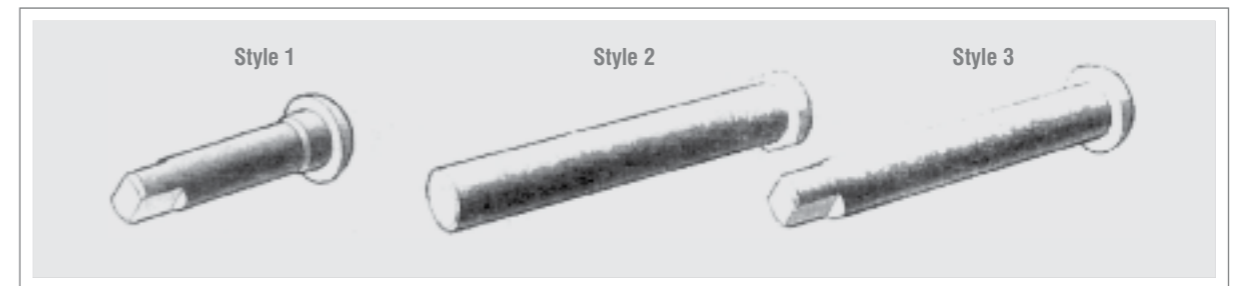

	Chain Number	Rivet Style	Rivet Dia.	Rivet Length Under Head	Approx. Weight
			mm		
Trimmer Chain	SO-578	3	9.5	49.2	4.5
	MS-88	3	11.1	57.2	7.3
	81-X, 3939	3	11.1	48.8	5.4
	MO-88	3	11.1	57.2	7.3
	LXS-882	3	11.1	60.3	6.8
Malleable Chain	C102-B	3	15.9	101.6	22.7
	C-131	1	15.9	82.6	21.8
	C-188	3	12.7	63.5	7.3
	H-78, H-130, H-138	2	12.7	77.8	8.2
	H-82	2	14.3	92.7	12.7
Mill Chain	WR-78, 78-4, 130, 138, 78 Rolltop	1	12.7	71.4	7.7
	WR-78 (5") XHD	1	14.3	88.9	11.8
	WR-78 XHD	1	14.3	78.6	11.8
	WR-82	1	14.3	79.4	11.8
	WR-82XHD/WR-720S	1	19.1	90.5	23.6
	WR-124, WR-106	1	19.1	101.6	26.3
	WR-111	1	19.1	117.5	29.0
	WR-144	1	25.4	104.8	44.0
	WR-124XHD/WR-106XHD	1	25.4	117.5	45.8
	WR-150, WR-WRC-132	1	25.4	152.4	62.6
	WR-WRC-132XHD	1	25.4	165.1	70.3
	WR-WRC-157, WR-155	1	28.6	166.7	85.3
	WHX-157XHD, WR-159	3	31.8	166.1	90.7
	WRC-131	1	19.1	82.6	23.6
	Drag Chain	WD-102	1	19.1	225.4
WD-104		1	19.1	169.9	40.1
WD-110, WD-112		1	19.1	292.9	68.0
WD-116		1	19.1	391.3	89.8
WD-113		1	22.2	303.2	95.3
WD-118		1	22.2	420.7	131.5
WD-118-1		1	25.4	420.9	168.7
WD-118XHD		1	25.4	431.8	172.4
WD-120, WD-122		1	22.2	303.2	95.3
WD-120XHD		1	25.4	328.6	126.1
WD-480		1	22.2	366.7	117.0
WD-480XHD		1	25.4	379.4	156.0
WD-480-1	1	22.2	360.4	151.5	

CAN-AM CHAINS manufactures a full range of chain products especially for the OSB Industry. Many of these are proprietary designs developed for specific applications.

Corrosion, shock loading, fatigue and wearability are common problems that we have generated solutions for.

Consult your "CAN-AM CHAINS" factory representative for details.

**LOG DECK CONVEYORS
BARKER INFEED CONVEYORS
HOT POND CONVEYORS
LOG TRANSFER CONVEYORS**

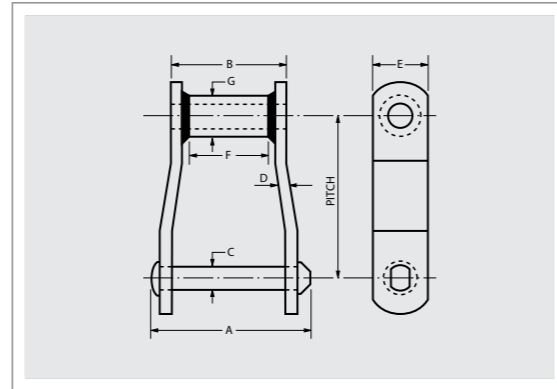

Chain Number	Pitch mm	Ultimate Strength Kg	Allowable Working Load Kg	Links Pcs./Mtr	Average Weight Kg/Mtr	Approx. Overall Width		Rivet Dia. C	Side Bar Thickness D	Side Bar Height E	Approx. Tooth Face at Pitch Line F	Outside Barrel Dia. G
						A	B					
WH-124 IBR	101.600	25,855	4,309	9.84	11.6	108.0	69.9	19.1	9.5	38.1	38.1	31.8
WH-124XHD IBR	103.200	55,339	9,253	9.84	21.7	123.8	76.2	25.4	12.7	50.8	38.1	41.3
WH-106XHD IBR	153.670	55,339	9,253	6.56	17.6	123.8	76.2	25.4	12.7	50.8	38.1	41.3
WH-132 IBR	153.670	55,339	9,208	6.56	21.0	161.9	111.9	25.4	12.7	50.8	69.9	44.5
WH-132XHD IBR	153.670	55,339	9,253	6.56	22.8	171.5	118.3	25.4	15.9	50.8	69.9	44.5
WH-150 IBR	153.670	55,339	9,253	6.56	24.3	165.1	111.9	25.4	12.7	63.5	69.9	44.5
WH-155 IBR	153.670	79,380	13,154	6.56	28.3	162.7	112.7	28.6	14.3	63.5	69.9	44.5
WH-157 IBR	153.670	83,916	13,608	6.56	29.8	171.5	117.5	28.6	15.9	63.5	69.9	44.5
WH-200 IBR	155.575	86,184	14,515	6.56	32.9	171.5	117.5	31.8	15.9	63.5	69.9	48.3
WH-159 IBR	155.575	95,256	15,876	6.56	34.2	171.5	117.5	31.8	15.9	76.2	69.9	48.3

All above chains are fully through hardened with further deep induction hardened rivets and barrels. See page 1 for technical specs.

RAKEBACK CONVEYORS

Chain Number	Pitch mm	Ultimate Strength Kg	Allowable Working Load Kg	Links Pcs./Mtr	Average Weight Kg/Mtr	Approx. Overall Width		Rivet Dia. C	Side Bar Thickness D	Side Bar Height E	Approx. Tooth Face at Pitch Line F	Outside Barrel Dia. G
						A	B					
WH-82XHD IBR	78.105	26,037	3,810	12.80	12.6	100.0	60.3	19.1	9.5	38.1	28.6	31.8
WH-124 IBR	101.600	25,855	4,309	9.84	11.6	108.0	69.9	19.1	9.5	38.1	38.1	31.8
WH-106 IBR	152.400	27,216	4,536	6.56	9.2	108.0	69.9	19.1	9.5	38.1	38.1	31.8
WH-144 IBR	101.600	38,556	6,441	9.84	18.6	109.5	69.9	25.4	9.5	44.5	38.1	41.3
WH-166 IBR	152.400	38,556	6,441	6.56	17.4	108.0	69.9	25.4	9.5	44.5	38.1	41.3
WH-124XHD IBR	103.200	55,339	9,253	9.84	21.7	123.8	76.2	25.4	12.7	50.8	38.1	41.3
WH-106XHD IBR	153.670	55,339	9,253	6.56	17.6	123.8	76.2	25.4	12.7	50.8	38.1	44.5
WH-132 IBR	153.670	55,339	9,253	6.56	21.0	165.1	111.9	25.4	12.7	50.8	69.9	23.6

All above chains are fully through hardened with further deep induction hardened rivets and barrels. See page 1 for technical specs.

SPECIAL SLOTTED A22 FOR RAKEBACK

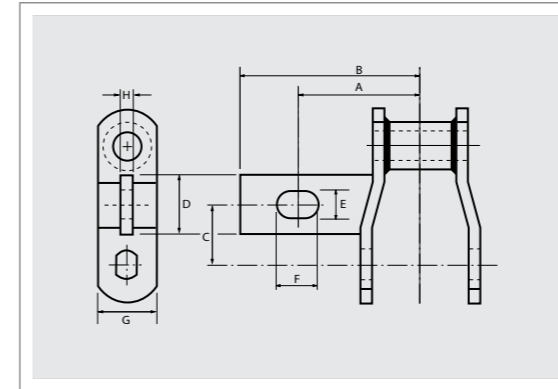

Chain Number	A	B	C	D	E	F	G	H
WH-124 IBR	101.6	150.8	44.5	50.8	20.6	38.1	38.1	12.7
WH-124XHD IBR	104.8	154.0	44.5	50.8	20.6	38.1	50.8	12.7
WH-106 IBR	101.6	150.8	44.5	50.8	20.6	38.1	38.1	12.7
WH-106XHD IBR	104.8	154.0	44.5	50.8	20.6	38.1	50.8	12.7
WH-132 IBR	114.3	158.8	76.2	50.8	20.6	38.1	50.8	12.7
WH-132 XHD IBR	117.5	161.9	76.2	50.8	20.6	38.1	50.8	12.7
WH-144 IBR	101.6	150.8	50.8	63.5	20.6	33.3	44.5	12.7
*WH-166 IBR	101.6	150.8	76.2	76.2	20.6	33.3	44.5	12.7
*WH-166 IBR (Option)	95.3	127.0	76.2	63.5	17.5	25.4	44.5	12.7

All above have Through Hardened Sidebars, Through Induction Hardened Barrels and Through & Induction Hardened Rivets.

APRON FEEDER

APRON FEEDER

RS 933-F

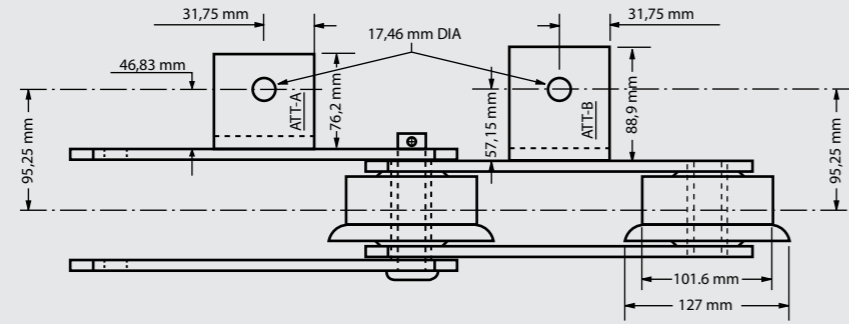

160 MM SPECIAL

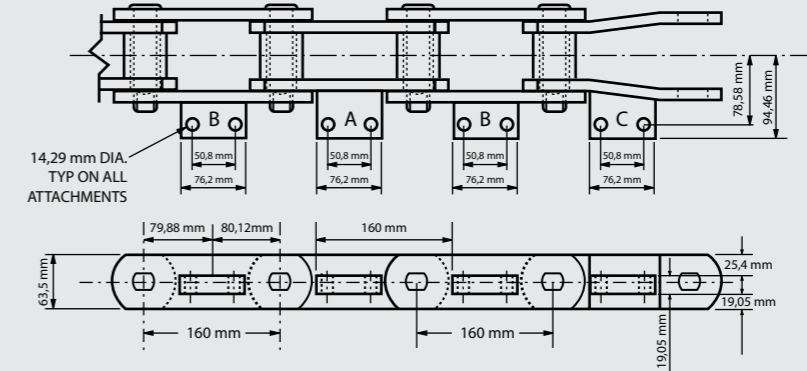

Comes with A-2 L & RH CAM 531 PI

RS 944

HD Pan Chain
CAM 955 PI

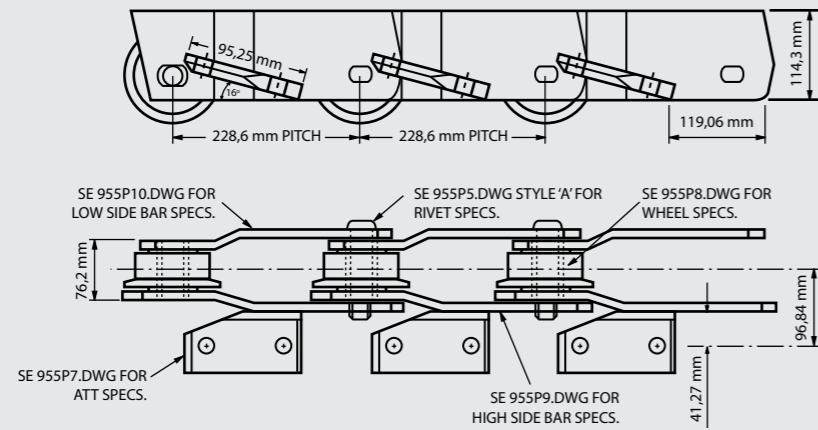

S 1209

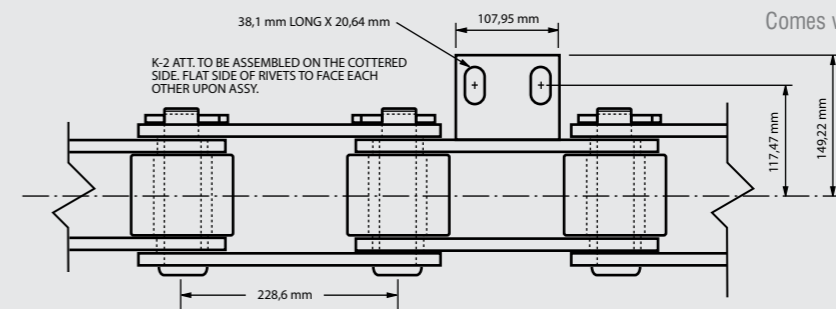

Comes with A-2 Attachment
CAM 0465

250MM

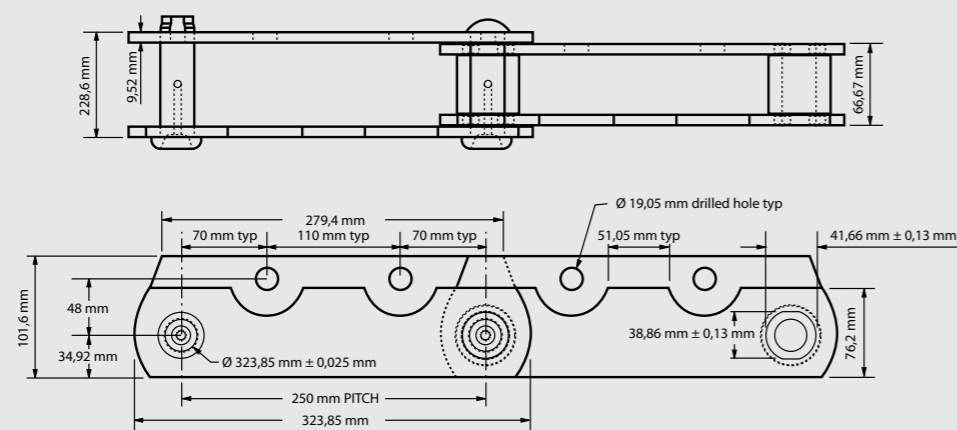

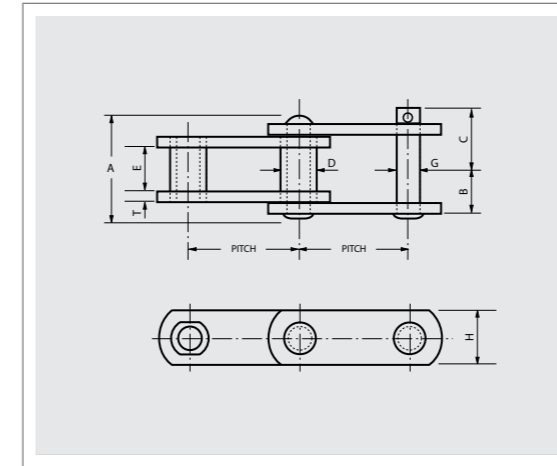
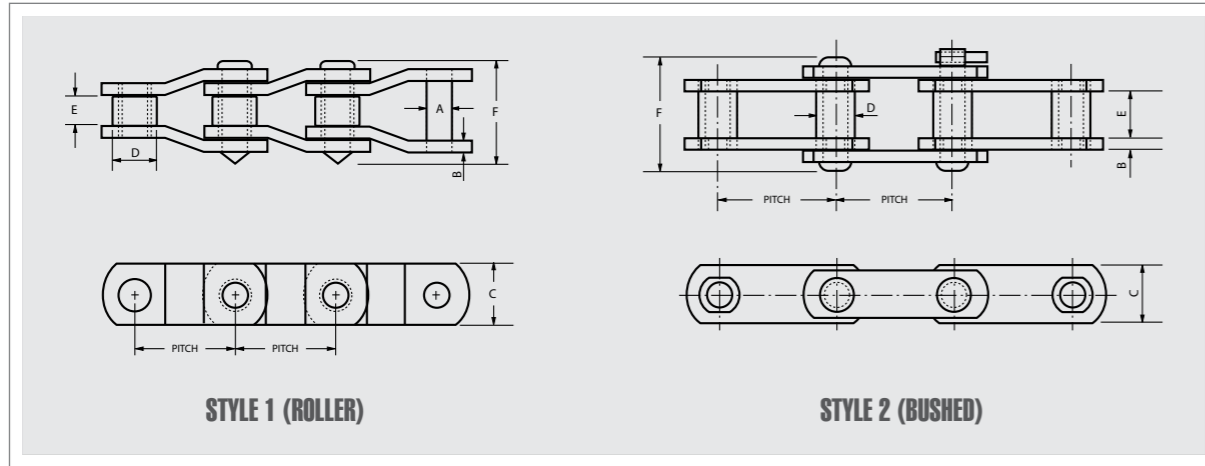

HB BUSHED CHAIN

Chain Number	Style	Pitch mm	Average Weight Kg/Mtr	Ultimate Strength Kg	Pin Diameter	Side Bar Thickness	Side Bar Height	Barrel/Roller Diameter	Max Sprocket Face	Width
					A	B	C	D	E	F
SB2512	1	77.902	19.6	49,896	19.1	9.5	57.2	41.1	38.1	99.1
SB3011	1	77.902	19.6	49,896	19.1	9.5	57.2	41.1	38.1	99.1
SB1242	1	103.200	23.2	63,504	22.2	12.7	57.2	44.5	48.3	121.9
SB1245	1	103.454	27.7	77,112	23.8	14.3	60.3	45.2	48.3	129.5
SB1254	1	103.124	27.7	77,112	23.8	12.7	57.2	45.2	30.5	108.0*
US-3075	1	78.105	14.3	34,020	16.5	9.7	44.5	31.8	38.1	93.5
US-4522	1	114.300	37.8	99,792	27.9	14.2	76.2	57.2	52.3	135.1

Commonly used sizes shown. Consult your CAN-AM Representative for other sizes.
*Note: Can also be flush welded rivets at 3 3/8 OAW.

Chain Number	Pitch mm	Width				Bushing		Pin		Side Bar			Avg. Ultimate Strength Kg	Max. Working Load Kg	Average Weight Kg/Mtr
		A	B	C	E	D	Material	G	Material	H	T	Material			
		mm				mm		mm		mm					
SB850	152.400	146.1	73.0	84.1	57.2	50.8	ACH	33.3	AIH	76.2	15.9	CHT	90,720	11,340	35.0
856	152.400	155.6	73.0	82.6	76.2	44.5	ACH	25.4	AIH	63.5	12.7	CHT	45,360	6,350	24.6
857	152.400	155.6	73.0	82.6	76.2	44.5	ACH	25.4	AIH	82.6 [ⓐ]	12.7	CHT	58,968	6,350	31.3
859	152.400	187.3	90.5	96.8	95.3	60.3	ACH	31.8	AIH	101.6 [ⓐ]	15.9	CHT	90,720	9,888	50.6

- ⓐ Outer plain side bars are 63,5 mm high
- ⓑ Outer plain side bars are 76,2 mm high

Material:
 CHT – Carbon Heat Treated
 CCH – Carbon Case Hardened
 AIH – Alloy Steel Induction Hardened
 ACH – Alloy Case Hardened

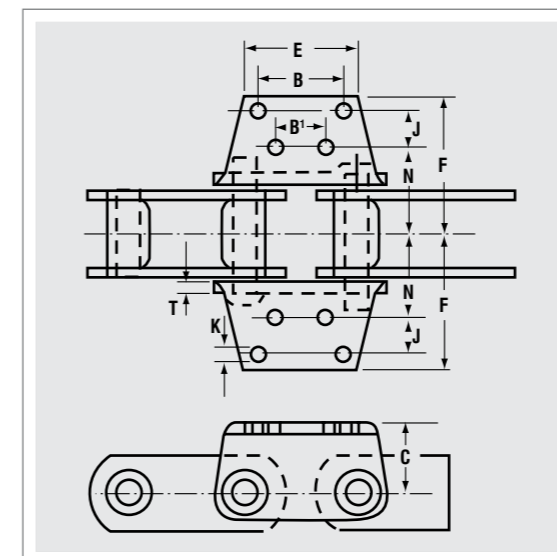

HB BUSHED CHAIN ATTACHMENTS

Attachment Number	Chain Number	Pitch	B	B'	C	E	F	J	K	N	T	Average Weight Kg/Mtr
K44	857	88.9	88.9	88.9	63.5	158.8	173.8	63.5	12.7	-	12.7	62.5
	859	114.3	114.3	69.9	76.2	165.1 [ⓐ]	191.7	50.8	15.9	-	15.9	99.7

- ⓐ With attachments on pin link

STEEL PINTLE CHAIN

'J' BAR SORTER CHAIN – 9" PITCH

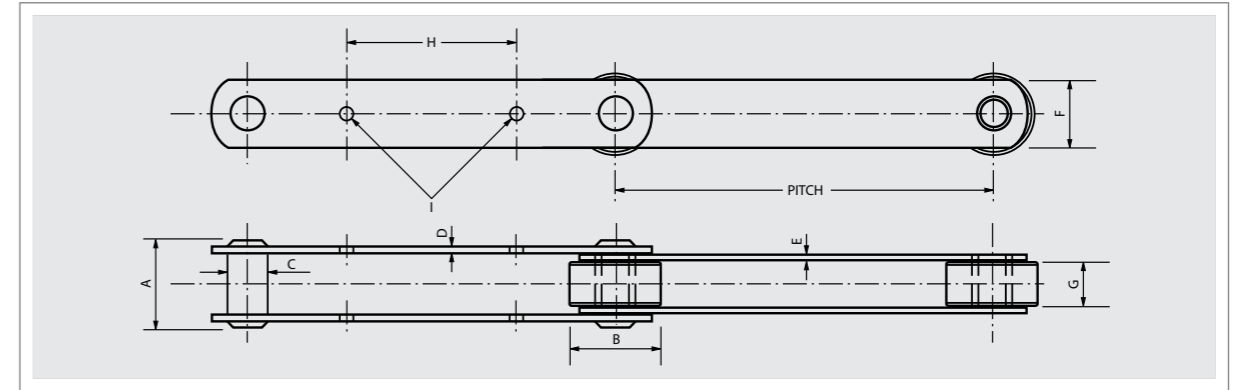
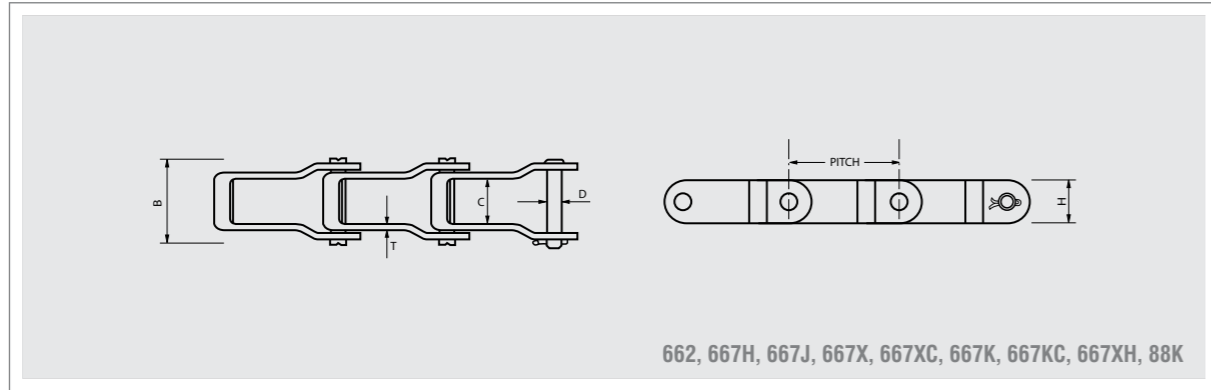

Chain Number	Links		Average Weight	Min. Adv. Tensile Strength	Pitch	Pin Diameter	Inside Width	Height	Thickness	Overall Width
	Pcs./Mtr	Kg/Mtr				D	C	H	T	B
						mm				
662	23.62	1.6	3,856	42.300	7.14	23.02	18.29	3.18	41.28	
667H	17.06	1.7	4,309	58.800	7.92	25.40	22.23	3.18	44.05	
667X	17.39	2.8	9,526	57.200	11.10	26.99	23.80	4.32	49.61	
667XC	17.39	3.1	8,165	57.200	11.10	26.99	23.80	4.32	49.61	
667K	17.39	3.6	9,072	57.200	11.10	27.38	26.97	5.08	53.98	
667KC	17.39	3.8	10,886	57.200	11.10	27.38	26.97	5.08	53.98	
667XH	17.39	4.2	12,701	57.200	11.91	27.38	26.97	5.69	58.74	
88K	15.09	3.4	9,072	66.300	11.10	27.38	26.97	5.08	53.98	

Chain Number	Pitch	Ultimate Strength	Overall Width Rivet	Roller Diameter	Pin Diameter	Outer Side Bar Thick	Inner Side Bar Thick	Side Bar Hight	Inside Width	Hole Centres	Hole Diameter
			A	B	C	D	E	F	G	H	I
			mm								
CAM 900STR	228.6	5,443	47.63	47.63	14.99	5.08	5.08	38.10	19.81	101.60	9.91
CAM 900HSTRHVY	228.6	6,804	53.98	47.63	16.26	6.35	6.35	38.10	17.53	101.60	9.91

'J' BAR SORTER CHAIN – 8" PITCH

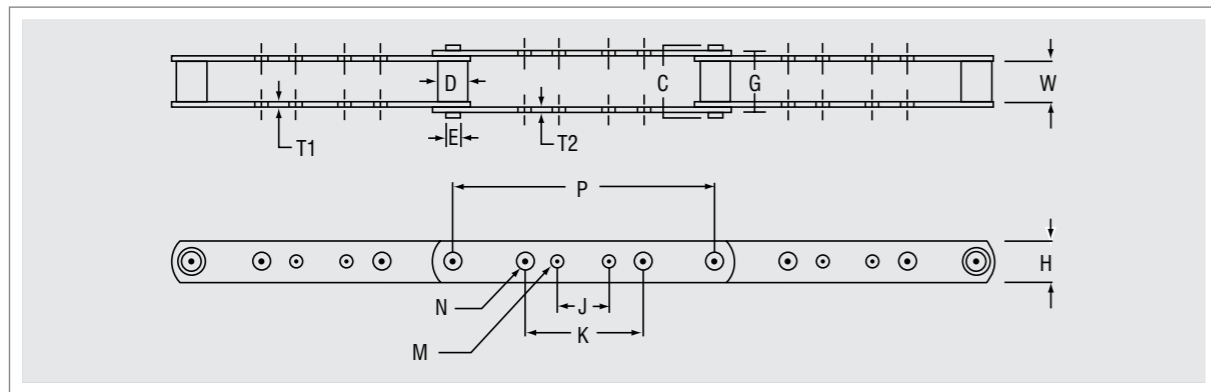

Chain Number	Links		Average Weight	Avg. Ultimate Strength	Pitch											
	Pcs./Mtr	Kg/Mtr				P	C	D	E	G	H	J	K	M	N	W
						mm										
3939*	4.92	2.3	10,886	203,200	49.02	22.86	10.97	44.20	28.58	38.10	91.95	7.11	10.41	26.92	3.94	3.94
3939-4	4.92	2.3	10,886	203,200	49.02	22.86	10.97	44.20	28.58	38.10	101.60	7.11	7.11	26.92	3.94	3.94
3939-H	4.92	3.6	16,783	203,200	58.42	22.86	10.97	50.80	28.58	38.10	101.60	7.11	7.11	26.92	6.35	6.35

* Sometimes referred to as 81X-8.

F-2 ATTACHMENTS

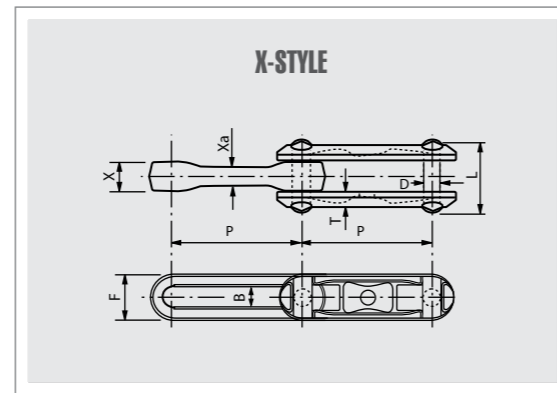
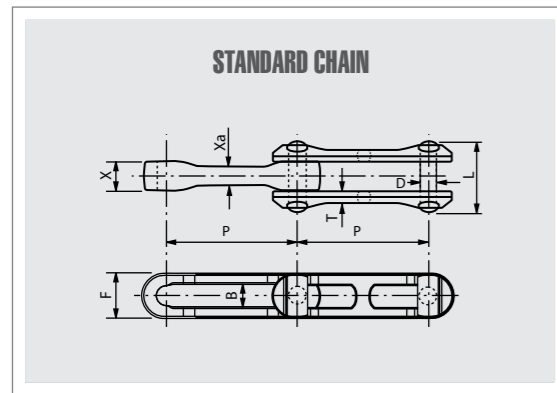

Chain Number	Reference Pitch	Width of centre link opening	Pin Diameter = Chain Height	F (max.)	Chain width over pins	Sidebar Thickness	Centre link width	Centre link width - secondary	Number of Pitches
	P	B (min.)	D		L (max.)	T	X	Xa	
mm									
Pcs./Mtr									
X-348	76.200	13.49	12.70	27.38	44.45	10.16	19.05	12.70	13.12
X-458	101.600	16.76	16.00	36.32	57.15	11.94	25.40	16.00	9.84
468	101.600	21.34	19.05	47.75	84.84	16.00	41.40	28.70	9.84
X-658	152.400	16.76	16.00	35.81	57.15	12.19	25.91	16.00	6.56
X-678	152.400	24.64	22.10	50.80	79.50	19.05	32.51	21.34	6.56
698	152.400	30.23	28.45	68.33	95.25	21.59	39.62	25.40	6.56
998	228.600	30.23	28.45	68.33	95.25	22.35	39.62	25.40	4.37
9118	228.600	36.83	35.05	79.50	123.95	31.75	49.28	33.27	4.37
9148	228.600	48.51	44.45	96.01	148.59	35.05	62.74	41.40	4.37

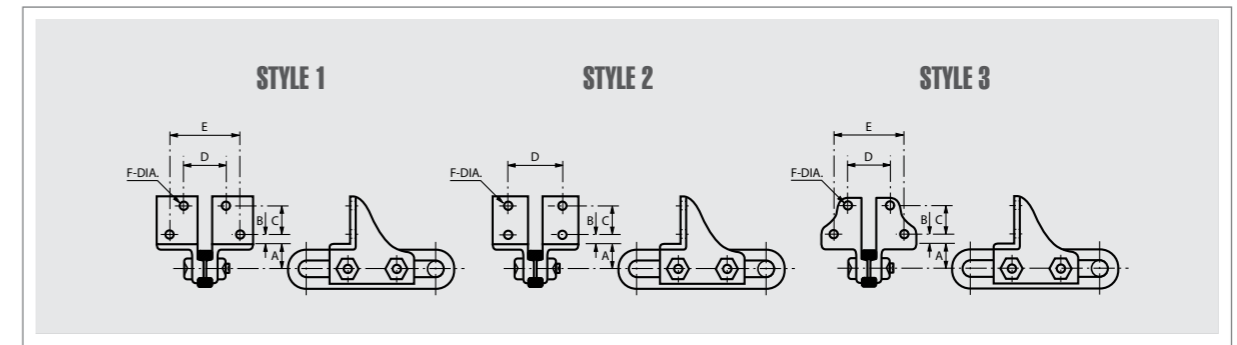

Type*	Chain Size	Style	Part Number	A	B	C	D	E	Bolt Diameter	Weight Each	Material**
				mm							
A	458	2	4F2C	20.64	25.40	1 hole	87.31		12.70	0.37	M.I.
A	468	2	4F2J	24.61	25.40	31.75	100.01		12.70	0.64	M.I.
A	468	2	4F2S	24.61	25.40	1 hole	100.01		12.70	0.42	M.I.
S	468	2	4F2D	23.81	41.28	1 hole	98.43		12.70	0.80	M.I.
A	678	1	6F2C	26.99	22.23	34.93	65.09	106.36	12.70	0.88	M.I.
A	678	3	6F2F	26.99	22.23	31.75	52.39	109.54	12.70	0.84	M.I.
A	698	2	6F2D	32.54	19.05	50.80	100.01		12.70	1.11	M.I.
A	998	2	9F2S	45.24	19.05	50.80	100.01		12.70	1.70	M.I.
A	998	2	9F2A	32.15	19.05	50.80	152.40		12.70	1.61	M.I.
A	998	3	9F2F	42.86	15.88	58.74	56.36	173.04	12.70	1.53	M.I.
A	998	2	9F2D	32.54	19.05	50.80	100.01		12.70	1.34	M.I.
A	9118	2	9F2C	41.28	15.88	50.80	101.60		12.70	1.77	M.I.
A	9148	1	9F2R	41.28	31.75	101.60	104.78	165.10	15.88	3.70	M.I.

*S - Side Link Attachment A - Bolted Centre Link Attachment **M.I. - Malleable Iron

S ATTACHMENTS

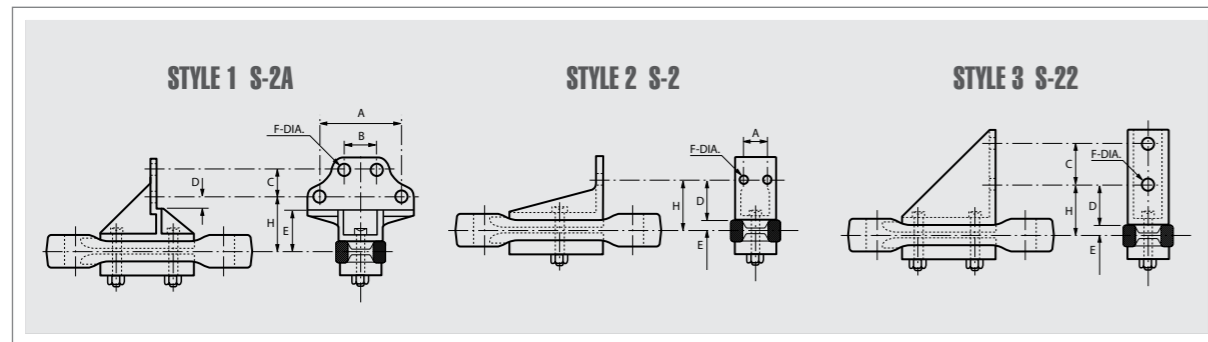

Chain Size	Style	Part Number	A	B	C	D	E	Bolt Diameter	Weight	Material*	
			mm								F
Kg											
458	3	4S2B			50.80	49.21	7.94	12.70	57.15	0.66	M.I.
468	2	4S2A	38.10			52.39	14.29	12.70	66.68	0.48	M.I.
468	3	4S2D			50.80	55.56	14.29	12.70	69.85	0.74	M.I.
678	2	6S2A	38.10			76.20	10.32	15.88	86.52	1.13	M.I.
678	1	6S2D	131.76	53.98				12.70	88.11	2.10	M.I.
678	3	6S2BK			57.15	65.09	10.32	15.88	75.41	1.51	M.I. & C.S.
698	3	6S2W			63.50	88.90	12.70	19.05	101.60	1.93	M.I. & C.S.
998	3	9S2A			76.20	69.85	12.70	19.05	82.55	3.63	M.I.
998	1	9S2A	131.76	53.98	44.45	36.51	63.50	12.70	100.01	3.67	M.I.
998	3	9S2D			163.51	88.90	12.70	15.88	101.60	4.76	M.I.
9118	3	9S2F			165.10	90.49	17.46	19.05	107.95	5.44	M.I.
9148	3	9S2C			163.51	93.66	20.64	19.05	114.30	5.49	C.S.

*M.I. - Malleable Iron, C.S. - Cast Steel

FILLER BLOCKS

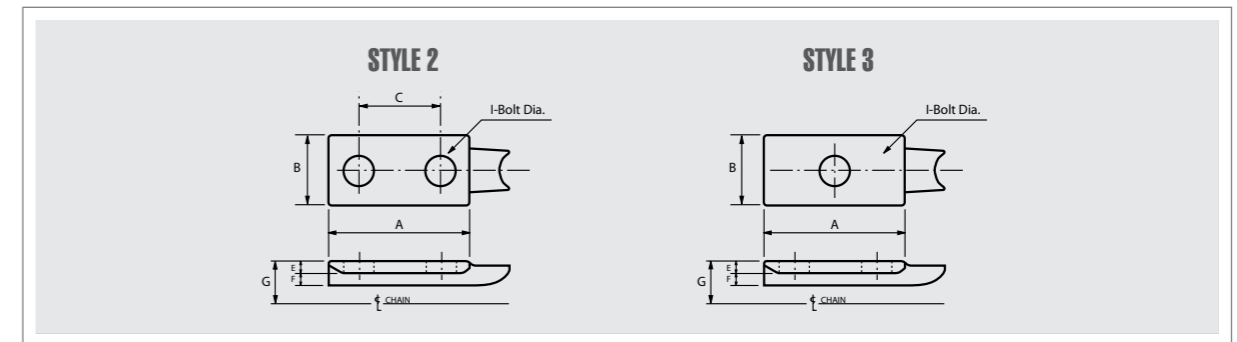

Chain Size	Style	Part Number	A	B	C	E	F	G	Bolt Diameter	Weight Each
			mm					I		
Kg										
458	3	4-A-3-B	57.15	34.93		7.94	7.94	15.88	12.70	0.27
468	3	4-A-3-A	47.63	36.51		7.94	11.11	22.23	12.70	0.27
678	3	6-A-3-B	92.08	46.04		7.94	7.94	18.26	15.88	0.41
698	3	6-A-3	75.41	60.33		8.73	11.11	21.43	19.05	0.42
998	2	9-A-3	151.61	60.33	95.25	9.53	11.11	22.23	15.88	0.79
9118	2	9-A-3-B	136.53	76.20	80.17	9.53	14.29	26.99	19.05	0.98
9148	2	9-A-3-R	111.13	82.55	63.50	9.53	17.46	30.16	19.05	1.27

*M.I. - Malleable Iron C.S. - Cast Steel

ENGINEERING NOTES

To provide the proper chain strength for your application, the data below illustrates the ultimate strength of the chain along with its recommended nominal working load. CDM Systems uses a 5.5:1 safety ratio for proper application.

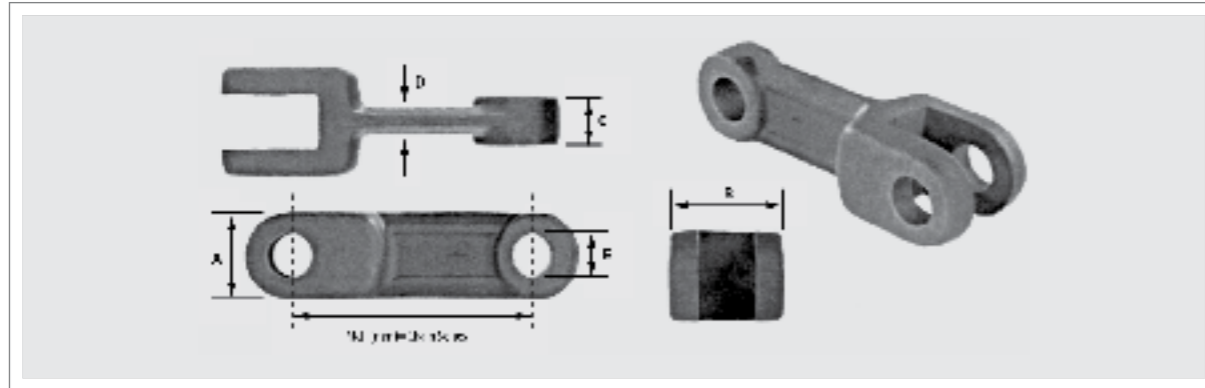

Chain Series	Ultimate Strength	Working Load	Weight						Recommended Sprocket Type
				A	B	C	D	E	
		Kg		mm					
102 HVY	17,275	3,135	0.45	35	32	14	9	18	Symmetrical ONLY
142 STD	33,180	5,910	1.11	50	42	19	12	25	Symmetrical
142 HVY	45,000	8,182	1.70	50	62	29	16	25	Symmetrical
142 STD/DBL	33,180	5,910	1.55	See table on page 50 for dimensional					Non-symmetrical
142 HVY/DBL	45,000	8,182	2.15	See table on page 50 for dimensional					Non-symmetrical
260 STD	68,180	12,390	6.40	75	70	30	20	32	Non-symmetrical

APPLICATIONS

Typical applications for the triple (TPL) series chains include single-strand flight widths up to 30", and, when used in tandem with DBL series chains (for triple strand widths), flight widths reaching up to 12'-0" (3.7m).

TECHNICAL NOTES

The retaining mechanisms used to fasten flights onto the TPL link are standard 142 series U-pins or optional 5/16" grade 8 bolts, identical to those used with the DBL-series link shown on page 50. Also available for the TPL link are single-slotted flights that can be made in a variety of materials, shapes and sizes. These can easily be slipped into the groove of the chain link and fastened with a set of U-pins. Contact CAN-AM for more details. Because of their unique design, 142 TPL links require the use of non-symmetrical sprockets ('TN' series) as illustrated on page 39.

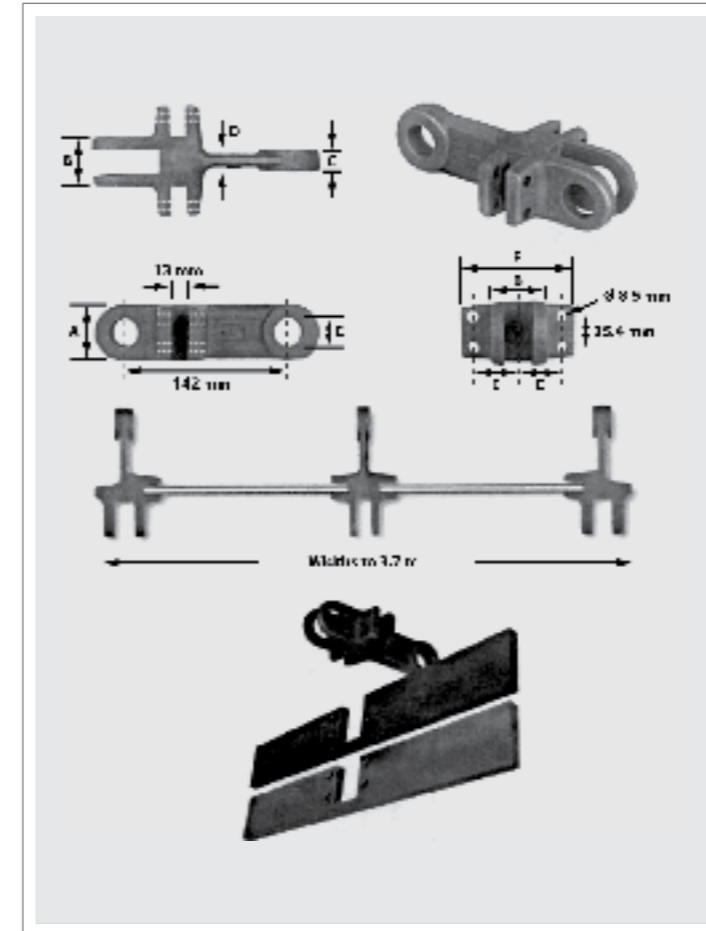

Chain Series	Ultimate Strength	Working Load	Weight						
				A	B	C	D	E	F
		Kg		mm					
142 STD/TPL	33,180	5,910	1.85	50	42	19	12	35.0	92.0
142 HVY/TPL	45,000	8,180	2.45	50	62	29	16	43.5	112.3

This chain type requires the use of non-symmetrical sprocket plates.

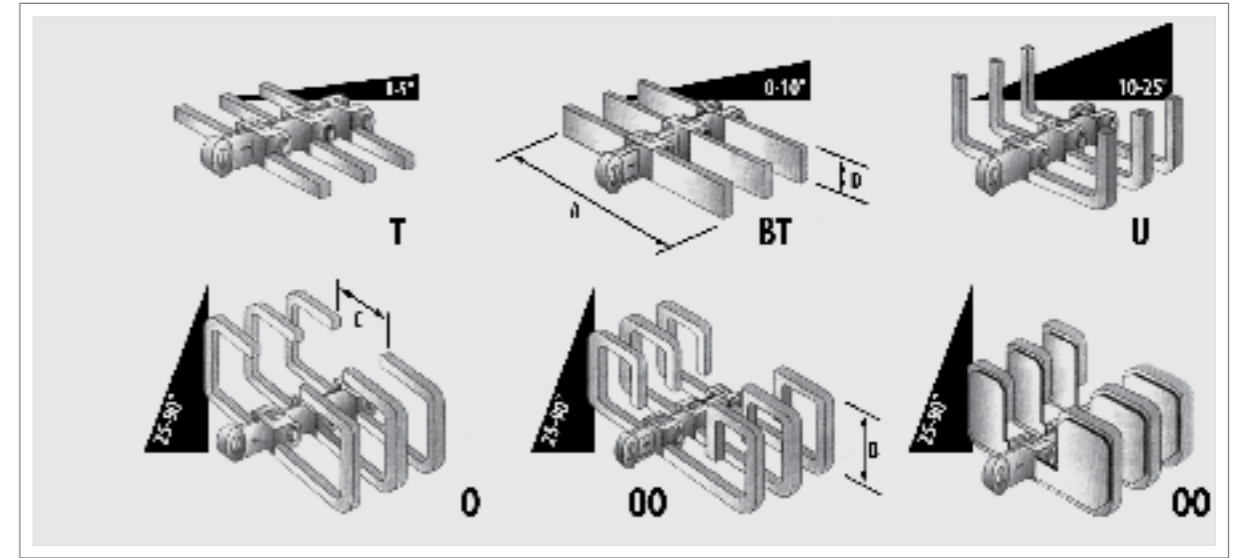
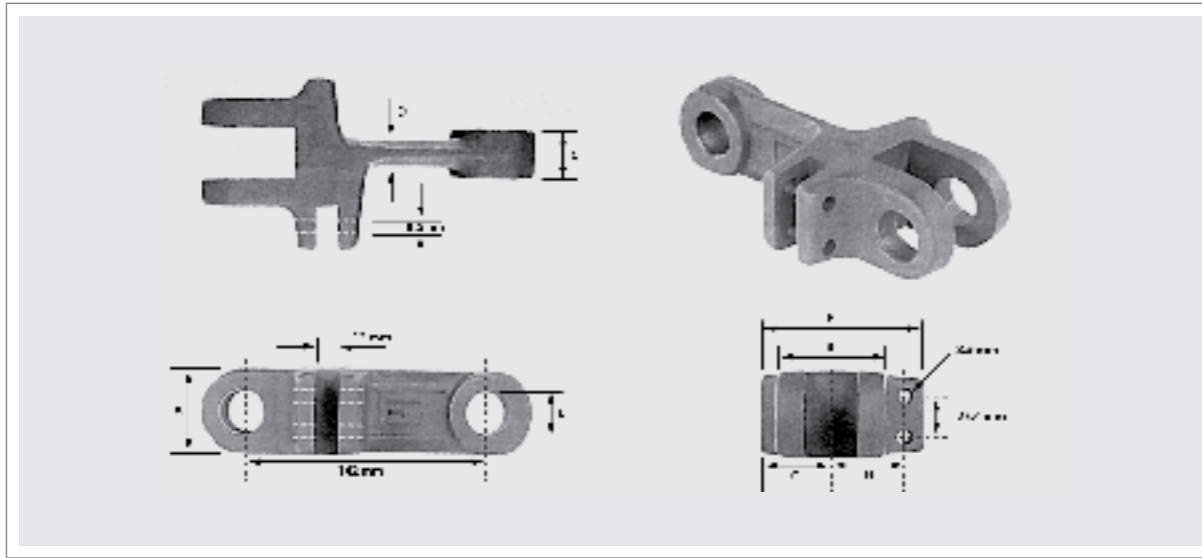

Chain Series	Ultimate Strength	Working Load	Weight	A	B	C	D	E	F	G	H
				mm							
142 STD/DBL	33,180	5,910	1.55	50.0	42.0	19.0	12.0	25.0	79.0	33.0	35.0
142 HVY/DBL	45,000	8,182	2.15	50.0	62.0	29.0	16.0	25.0	99.0	43.0	43.5

This chain type requires the use of non-symmetrical sprocket plates.

TO CALCULATE:

- Sprocket Centres:** Subtract J from the overall chain width
- Flight Length:** Subtract K from the overall chain width
- Hole Centres:** Subtract L from the overall chain length

NOTE:

Use non-symmetrical sprockets. Flights over 2" high should be notched for sprocket clearance.

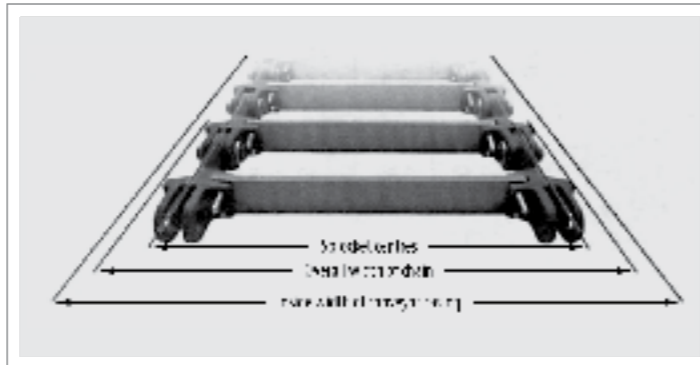

DOUBLE SERIES FLIGHTS

The DBL-series flight cutaway diagram shows the slots located at each end of the flight, which allow for expansion and contraction during operation. One U-pin connector connects each end of this type of flight to a DBL-series chain link. In applications where the flight operates under unusually heavy loads or extreme widths, a stiffener is welded to the back of the flight for extra stability. Although the U-pin is the most common (and preferred) method of fastening DBL flights, 5/16" (8mm) grade-8 bolts can be substituted.

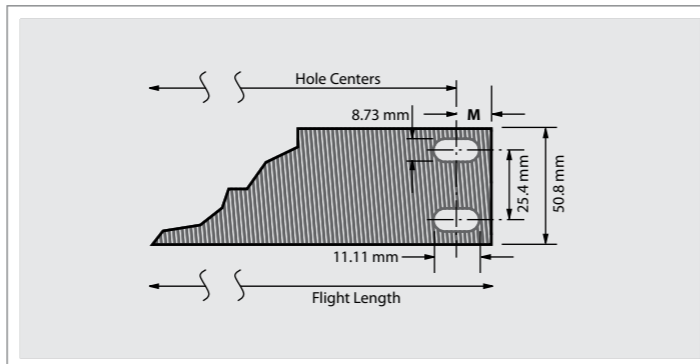

Chain Style	J	K	L	M
	mm			
142 STD/DBL	66.0	111.0	26.8	13.4
142 HVY/DBL	86.0	151.0	22.0	11.0

Chain Series	Conveyor Size	A	B	C	D	Weight (Flights only*)					
		mm				T	BT	U	O	OO	OO*
		Kg									
102 Series	254	250.0	114.3	76.2	35	-	1.00	-	1.14	1.27	-
	305	300.0	114.3	76.2	35	-	1.14	-	1.27	1.41	-
	356	352.0	114.3	76.2	35	-	1.27	-	1.50	1.60	-
	406	397.0	114.3	76.2	35	-	1.41	-	1.60	1.70	-
142 STD	280	278.0	149.5	120.7	50	0.64	1.07	1.41	1.65	2.00	2.55
	380	378.0	192.0	139.7	50	0.93	1.55	1.95	2.48	3.09	4.26
	480	478.0	254.0	158.7	50	1.24	2.02	2.59	3.25	4.21	6.40
	635	627.0	254.0	158.7	50	1.64	2.73	3.00	4.12	5.11	8.27
	762	757.2	254.0	158.0	50	2.01	3.36	3.38	4.85	5.86	9.85

DESIGNATING FLIGHTS:

- BT-1 Flight every link
- BT-2 Flight every 2nd link, etc.

APPLICATIONS

The flights illustrated above represent the most frequently demanded designs in the industry and are by no means the only styles available. The T and BT style flights are used for horizontal through slight incline applications, normally between 0 to 10°, while the U flight can be used for horizontal/incline combinations through approximately 25°. The Modified BT, O, OO, and OO with filler plates are utilized in horizontal/inclined applications through 90° (vertical).

TECHNICAL DATA

The flight configurations represented above can handle the majority of your material handling requirements. The letter designator represents the style of the flight, while the number designates its frequency among links.

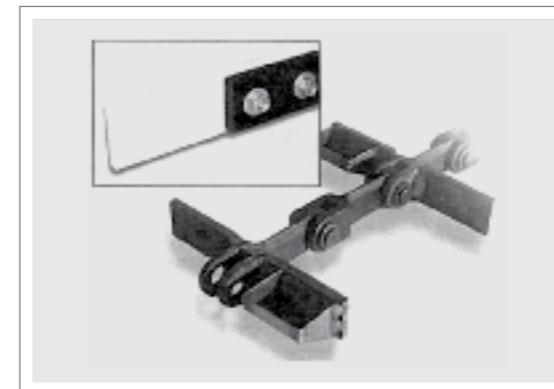

Leaf chains are well-suited for any application requiring flexible, high-strength linkage for reciprocating motion or lifting at relatively low speed. For their low cost and long life, these chains are widely used for lift trucks, masts and other lifting as well as construction, mining machines and balance or counterweights of machine tools.

CONSTRUCTION AND LACING COMBINATIONS

Built of interlaced plates held together by riveted pins. The chain nomenclature indicates the lacing combinations.

AL SERIES (LIGHT DUTY)

Consisting of link plates of the same contour and thickness as the pin link plates of ANSI roller chains in the same pitch. Mainly used for relatively constant, low, medium load with less shock.

BL SERIES (HEAVY DUTY)

Consisting of link plates with the thickness of the next larger size of ANSI roller chain. Chiefly used for medium load with greater shock.

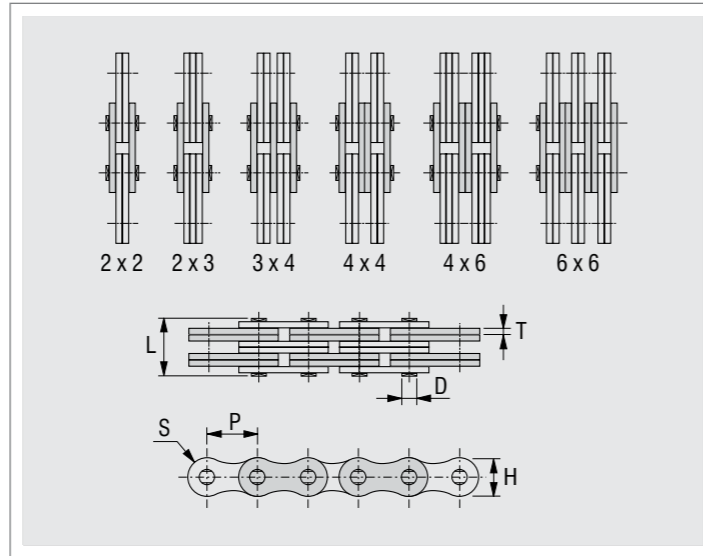

Chain Number	Lacing	Pitch	Pin Diameter	Pin Length	Plate Height	Plate Thickness	Hole Diameter	Average Weight	Average Ultimate Strength
		P	D	L	H	T	S (min.)		
mm								Kg/Meter	N
AL 422	2 x 2	12.700	3.962	8.407	10.312	1.524	4.059	0.357	1,814.400
AL 444	4 x 4			14.910				0.699	3,628.800
AL 466	6 x 6			21.107				1.042	5,443.200
AL 522	2 x 2	15.875	5.080	10.795	12.700	2.032	5.128	0.580	2,993.760
AL 544	4 x 4			19.304				1.161	5,987.520
AL 566	6 x 6			27.991				1.726	8,981.280
AL 622	2 x 2	19.050	5.944	13.970	15.189	2.388	6.030	0.804	4,245.696
AL 644	4 x 4			22.708				1.682	8,491.392
AL 666	6 x 6			32.893				2.456	12,737.088
AL 822	2 x 2	25.400	7.925	16.891	20.193	3.175	7.998	1.414	7,257.600
AL 844	4 x 4			29.693				2.887	14,515.200
AL 866	6 x 6			43.307				4.226	21,772.800
AL 1022	2 x 2	31.750	9.525	19.888	24.511	3.962	9.589	2.456	10,977.120
AL 1044	4 x 4			36.500				4.807	21,954.240
AL 1066	6 x 6			53.797				7.233	32,931.360
AL 1222	2 x 2	38.100	11.100	24.511	29.210	4.750	11.219	3.348	14,515.200
AL 1244	4 x 4			43.993				6.578	29,030.400
AL 1266	6 x 6			63.703				9.822	43,545.600
AL 1422	2 x 2	44.450	12.700	28.296	34.188	5.563	12.819	4.985	20,865.600
AL 1444	4 x 4			51.511				9.554	41,731.200
AL 1466	6 x 6			73.889				14.123	62,596.800
AL 1622	2 x 2	50.800	14.275	32.080	40.310	6.350	14.399	6.355	27,488.160
AL 1644	4 x 4			58.699				12.620	54,976.320
AL 1666	6 x 6			85.090				18.870	82,464.480

Chain Number	Lacing	Pitch	Pin Diameter	Pin Length	Plate Height	Plate Thickness	Hole Diameter	Average Weight	Average Ultimate Strength
		P	D	L	H	T	S (min.)		
mm								Kg/Meter	N
BL 422	2 x 2	12.700	5.080	10.795	11.760	2.032	5.128	0.640	2,766.960
BL 423	2 x 3			12.802				0.789	2,766.960
BL 434	3 x 4			17.094				1.071	4,173.120
BL 444	4 x 4			19.304				1.220	5,533.920
BL 446	4 x 6			23.495				1.577	5,533.920
BL 466	6 x 6			27.991				1.890	8,346.240
BL 522	2 x 2	15.875	5.944	12.700	14.656	2.388	6.030	1.012	4,082.400
BL 523	2 x 3			15.291				1.191	4,082.400
BL 534	3 x 4			20.498				1.607	6,168.960
BL 544	4 x 4			22.708				1.801	8,164.800
BL 546	4 x 6			28.092				2.262	8,573.040
BL 566	6 x 6			32.893				2.649	12,337.920
BL 622	2 x 2	19.050	7.925	17.094	17.551	3.175	8.009	1.533	6,486.480
BL 623	2 x 3			19.812				1.890	6,486.480
BL 634	3 x 4			26.695				2.679	9,729.720
BL 644	4 x 4			29.693				3.036	12,972.960
BL 646	4 x 6			36.906				4.152	12,972.960
BL 666	6 x 6			43.409				4.584	19,459.440
BL 822	2 x 2	25.400	9.525	19.888	24.130	3.962	9.599	2.575	10,478.160
BL 823	2 x 3			24.308				3.170	10,478.160
BL 834	3 x 4			32.791				4.375	15,785.280
BL 844	4 x 4			36.703				4.956	20,956.320
BL 846	4 x 6			45.390				6.236	20,956.320
BL 866	6 x 6			53.899				7.441	31,570.560
BL 1022	2 x 2	31.750	11.100	24.511	29.312	4.750	11.199	3.735	15,422.400
BL 1023	2 x 3			28.905				4.643	15,422.400
BL 1034	3 x 4			39.091				6.503	23,133.600
BL 1044	4 x 4			44.094				7.411	30,844.800
BL 1046	4 x 6			53.797				9.212	30,844.800
BL 1066	6 x 6			63.805				11.072	46,267.200
BL 1222	2 x 2	38.100	12.700	28.296	35.103	5.563	12.819	4.777	20,230.560
BL 1223	2 x 3			34.595				6.459	20,230.560
BL 1234	3 x 4			45.898				9.048	30,345.840
BL 1244	4 x 4			51.105				10.269	40,461.120
BL 1246	4 x 6			62.992				11.861	40,461.120
BL 1266	6 x 6			73.990				14.406	60,691.680
BL 1422	2 x 2	44.450	14.275	32.182	40.894	6.350	14.389	7.247	27,488.160
BL 1423	2 x 3			39.192				8.899	27,488.160
BL 1434	3 x 4			52.095				11.608	41,232.240
BL 1444	4 x 4			58.801				12.873	54,976.320
BL 1446	4 x 6			71.603				17.858	54,976.320
BL 1466	6 x 6			85.192				22.338	82,464.480
BL 1622	2 x 2	50.800	17.450	36.195	46.711	7.137	17.620	9.777	38,238.480
BL 1623	2 x 3			44.094				12.084	38,238.480
BL 1634	3 x 4			59.284				16.846	57,357.720
BL 1644	4 x 4			66.294				18.855	76,476.960
BL 1646	4 x 6			80.594				23.945	76,476.960
BL 1666	6 x 6			96.596				28.543	114,715.440
BL 2022	2 x 2	63.500	23.774	47.981	59.792	9.525	23.848	14.376	56,246.400
BL 2023	2 x 3			57.988				17.829	56,246.400
BL 2034	3 x 4			77.978				24.823	84,369.600
BL 2044	4 x 4			87.884				28.320	112,492.800
BL 2046	4 x 6			107.899				35.270	112,492.800
BL 2066	6 x 6			136.982				41.833	168,739.200

Nytro-PVL and Can-Am "ICE"

NYTRO-PVL

Nytro-PVL is a high performance Engineered Plastic developed for high-speed roller, sharptop, and sharp chain applications.

Nytro-PVL high PV (pressure velocity) and self-lubricating features extend chain life by absorbing impact and lowering operating temperatures, resulting in the reduction of costly downtime.

Nytro-PVL chain beds are custom machined to meet rigid dimensional tolerances for specific chain types, and, holds those tolerances better than steel.

Nytro-PVL dramatically reduces lubrication cost and lowers operating noise decibel levels



EXTREME DUTY

CAN-AM "ICE"

Can-Am "ICE" is a high performance wear material designed for high load, and tough abrasive applications.

The mechanical properties of Can-Am "ICE" have been modified to increase it's hardness and dimensional stability.

This uniqueness makes Can-Am "ICE" ideal for heavy Mill and Drag chain wear plate applications.

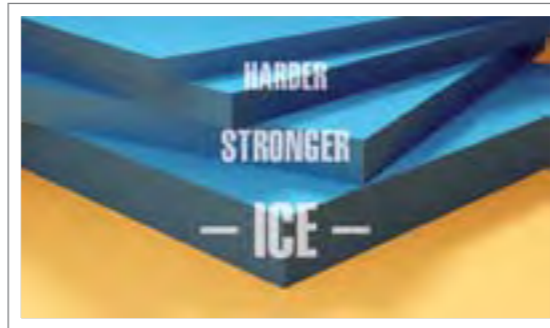

HIGH PERFORMANCE UHMW



- Maintenance free permanent magnetic power
- Fast change out, eliminating welding, gouging and grinding
 - Prevention of weld crystallization
 - Noise and vibration dampening
- Custom designs available to meet specific applications

Magna-Plate™ and Magna-Wedge™

MAGNA-PLATE™

MAGNETIC WEAR PLATE FASTENING SYSTEM

MAGNA-PLATE™ is a highly efficient method of wear plate attachment. This product combines powerful magnetic elements in flexible elastomeric compounds. MAGNA-PLATE™ offers a quick, clean and safe method to attach wear plate.

- Available in three models:
1. Standard
 2. High Impact
 3. Wet Application

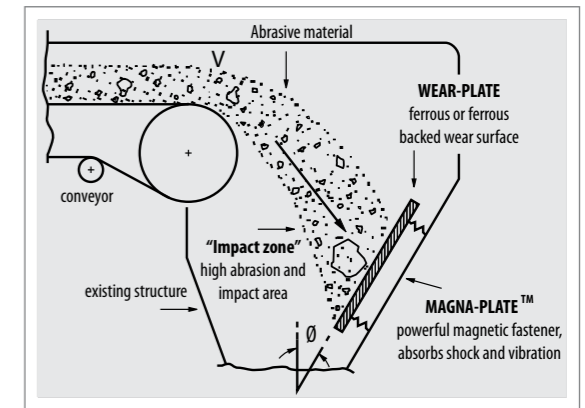

MAGNA-WEDGE™

TRAMP METAL SEPARATOR

- Quick and simple installation**
- installs in minutes utilizing the patented MAGNA-PLATE™ fastening system
 - applications include vibratory feeders, chutes and hoppers

- Decreased maintenance costs**
- capture and retain ferrous tramp metal before entering process equipment
 - protect chippers, hogs, grinders and other size reduction equipment

- Increased uptime**
- reduce unnecessary metal detector tripping
 - enhanced metal detector performance while permitting higher sensitivity

- Quality built**
- manufactured out of tough polyurethane, providing years of service
 - permanent magnetic power guaranteed to maintain strength

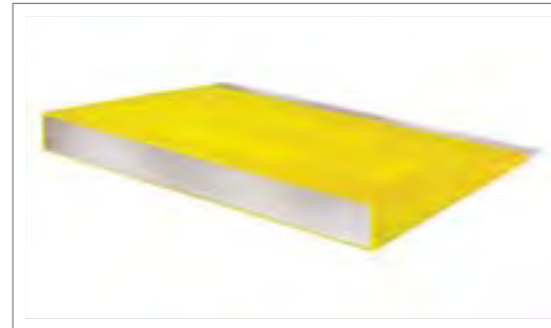

www.magna-skin.com

2500 SERIES CAN-AM BEARINGS features include:

- Less down time: 3 piece design allows for quick repair of bearing while base remains in place. Simply jack up shaft 1/4", lift out cap and insert, and replace.
- Recessed grease fittings in castings to prevent damage.
- Excellent for log deck application and any larger slow-moving shafts, rollcases, etc.
- Can be mounted in any position
- Base is fab. or cast steel
- 4 choices of bushing material:
 - urethane
 - bronze
 - babbitt
 - zinc aluminium
 - nytro PVL
- Steel base and ductile iron insert.

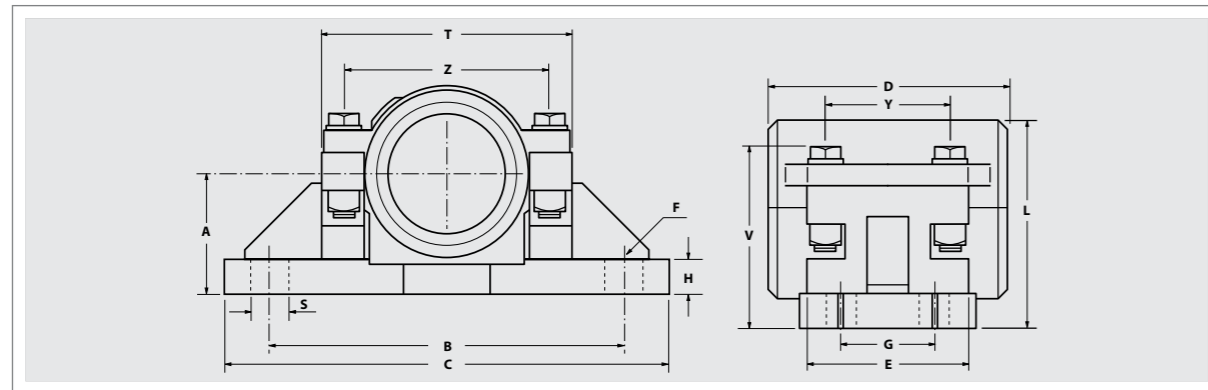
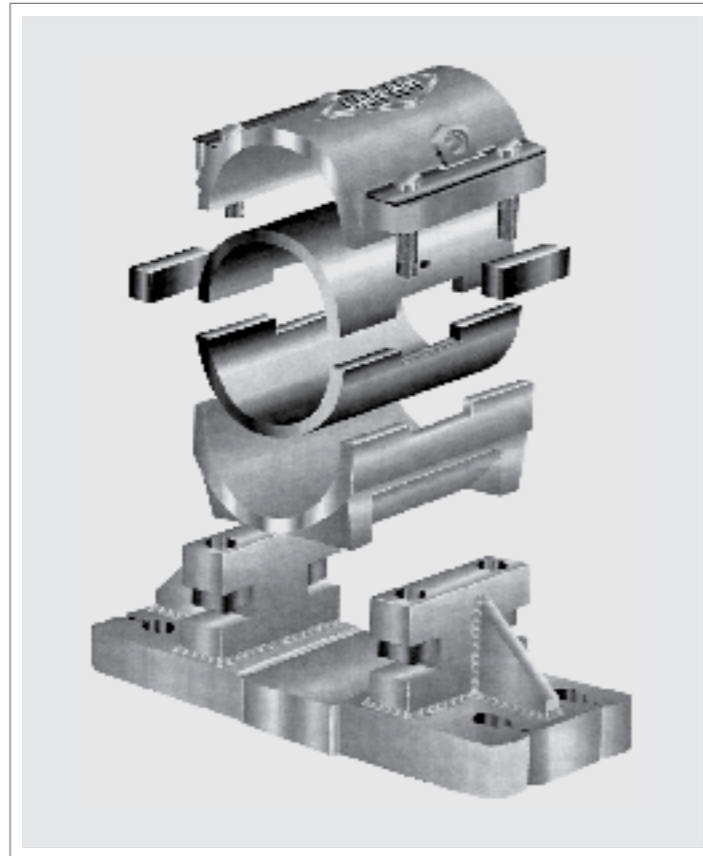

	A	B	C	D	E	F	G	H	L	S	T	V	Y	Z	Weight
	mm														Kg
2-2500 SERIES (4 BOLT)															
61.91	69.85	203.20	260.35	127.00	95.25	15.88	50.80	25.40	127.00	25.40	142.88	111.13	69.85	120.65	11.34
74.61	82.55	222.25	279.40	152.40	107.95	15.88	63.50	25.40	142.88	25.40	152.40	127.00	80.96	127.00	15.88
87.31	88.90	266.70	330.20	177.80	120.65	19.05	69.85	25.40	161.93	31.75	184.15	133.35	92.08	152.40	20.87
100.01	95.25	304.80	374.65	203.20	133.35	19.05	76.20	31.75	174.63	34.93	193.68	142.88	101.60	165.10	29.03
112.71	104.78	342.90	419.10	228.60	158.75	22.23	88.90	31.75	193.68	38.10	225.43	152.40	123.83	190.50	40.82
125.41	114.30	381.00	457.20	254.00	177.80	22.23	101.60	31.75	215.90	41.28	241.30	165.10	139.70	203.20	52.16
138.11	139.70	419.10	520.70	304.80	215.90	28.58	127.00	38.10	254.00	47.63	304.80	193.68	171.45	257.18	90.72
150.81	139.70	419.10	520.70	304.80	215.90	28.58	127.00	38.10	254.00	47.63	304.80	193.68	171.45	257.18	90.72
163.51	165.10	482.60	584.20	355.60	254.00	31.75	152.40	50.80	292.10	50.80	358.78	222.25	193.68	304.80	136.08
176.21	165.10	482.60	584.20	355.60	254.00	31.75	152.40	50.80	292.10	50.80	358.78	222.25	193.68	304.80	136.08
188.91, 201.61, 203.20	177.80	546.10	660.40	406.40	279.40	31.75	171.45	44.45	330.20	57.15	431.80	247.65	215.90	365.13	217.73
2500 SERIES (2 BOLT)															
61.91	69.85	203.20	260.35	127.00	95.25	19.05	-	25.40	127.00	28.58	142.88	111.13	69.85	120.65	11.34
74.61	82.55	241.30	311.15	152.40	107.95	22.23	-	25.40	142.88	34.93	152.40	127.00	80.96	127.00	15.88

1000 SERIES BEARINGS

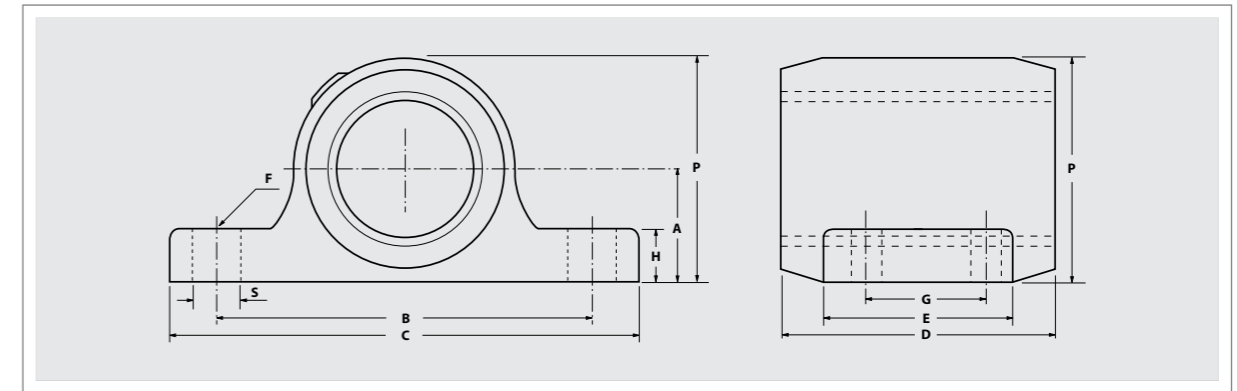

	A	B	C	D	E	F	G	H	P	S	Weight
	mm										Kg
2-1000 SERIES - 4 BOLT BASE											
61.91	57.15	177.80	234.95	127.00	101.60	15.88	50.80	28.58	111.13	28.58	6.35
74.61	63.50	222.25	285.75	152.40	114.30	15.88	63.50	31.75	123.83	28.58	10.89
87.31	76.20	254.00	317.50	177.80	127.00	19.05	69.85	34.93	152.40	31.75	16.33
100.01	82.55	279.40	349.25	203.20	139.70	19.05	76.20	38.10	165.10	34.93	23.13
112.71	104.78	342.90	419.10	228.60	158.75	22.23	88.90	44.45	200.03	38.10	34.02
125.41	114.30	381.00	457.20	254.00	177.80	22.23	101.60	47.63	215.90	41.28	45.36
1000 SERIES - 2 HOLE BASE											
49.21	44.45	152.40	203.20	101.60	69.85	15.88	-	22.23	88.90	25.40	3.63
55.56	50.80	165.10	215.90	114.30	76.20	15.88	-	25.40	98.43	25.40	4.99
61.91	57.15	177.80	234.95	127.00	82.55	19.05	-	28.58	111.13	28.58	6.35
74.61	63.50	215.90	285.75	152.40	101.60	22.23	-	31.75	123.83	34.93	10.89

Available in Babbitt, Urethane, Zinc-Aluminium & Bronze bushed. Grease fittings are 45° and countersunk into casting to prevent damage. All bearings have ductile housings, and have machine mounting surfaces.

METRIC BORES ALSO AVAILABLE

BEARING LOAD RATING

BEARING LOAD RATING TABLES

The following load rating tables apply when the following installations and operating conditions are met:

1. Maintain adequate grease lubrication. Use of EP grease is recommended.
2. Align bearings with shaft for uniform load distribution.
3. Normal running loads should not exceed ratings shown in load tables. Starting & occasional peak loads should not exceed ratings by more than 100%.
4. The journal shaft surface should be equal to that of commercial steel shafting (about 32 micro-inches) and the diameter within the tolerances of commercial steel shafting.
5. Ambient temperature should not exceed 130° F for babbitt, 300° F for bronze, 250° F for ZA and 225° F for urethane bushed bearings. If the shaft transmits heat from a source such as an oven, the shaft temperature at the bearing should not exceed these temperatures.
6. Where thrust loads are present, install a bronze washer and fasten it in place with a set collar against end of bearing. The bearing ends are finished.

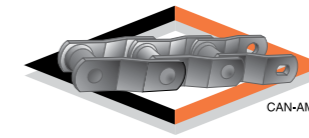

SPROCKET INFORMATION GUIDE

MILL CHAIN SPROCKETS

MILL CHAIN SPROCKETS CD.

Chain Number	Number of Teeth	Pitch Diameter	Max. Bore	Tooth Face
	Pcs.	mm	mm	
WR-111 PITCH=120.9 mm	8	315.98	125.41	50.80
	9	353.31	125.41	50.80
	10	391.16	125.41	50.80
	11	429.26	150.81	50.80
	12	467.11	150.81	50.80
	13	505.21	150.81	50.80
	14	543.31	150.81	50.80
	16	619.76	150.81	50.80
	17	657.86	150.81	50.80
	18	696.21	150.81	50.80
	20	772.92	150.81	50.80
24	926.34	150.81	50.80	
26	1 003.05	150.81	50.80	
28	1 079.75	150.81	50.80	

Chain Number	Number of Teeth	Pitch Diameter	Max. Bore	Tooth Face
	Pcs.	mm	mm	
WR-132	8	401.57	150.81	69.85
WRC-132	9	449.33	176.21	69.85
WR-132XHD	10	497.33	176.21	69.85
WRC-132XHD	11	545.34	176.21	69.85
WR/WH-157	12	593.85	176.21	69.85
WH-200	13	642.11	176.21	69.85
WR-150	14	690.63	176.21	69.85
WR-155	15	739.14	176.21	69.85
WR-159	16	787.65	176.21	69.85
PITCH=153.67 mm	18	884.94	176.21	69.85

Most flame cut sprockets, finished bore K+S.S. or T.K. are supplied from stock. Hardened sprockets also available.

DRAG CHAIN SPROCKETS

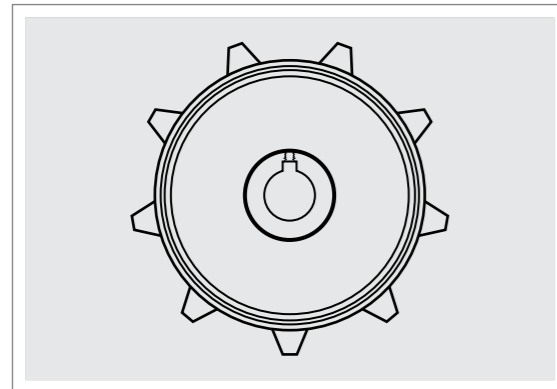

Chain Number	Number of Teeth	Pitch Diameter	Max. Bore	Tooth Face
	Pcs.	mm	mm	
WD-102 PITCH=127 mm	6	254.00	100.01	161.93
	8	331.98	150.81	161.93
	9	371.35	150.81	161.93
	10	410.97	150.81	161.93
	12	490.73	150.81	161.93
WD-104 PITCH=152.4 mm	8	398.27	125.41	104.78
	9	445.52	150.81	104.78
	10	493.27	150.81	104.78
WD-110 WD-113 PITCH=152.4 mm	6	304.80	112.71	228.60
	8	398.27	150.81	228.60
	9	445.52	150.81	228.60
WD-112 PITCH=203.2 mm	7	468.38	125.41	228.60
	8	530.86	150.81	228.60
	9	594.11	150.81	228.60

Chain Number	Number of Teeth	Pitch Diameter	Max. Bore	Tooth Face
	Pcs.	mm	mm	
WD-116 PITCH=203.2 mm	7	468.38	138.11	330.20
	8	530.86	150.81	330.20
	9	594.11	150.81	330.20
WD-118 PITCH=203.2 mm	7	468.38	138.11	330.20
	8	530.86	150.81	330.20
	9	594.11	150.81	330.20
WD-120 PITCH=152.4 mm	6	304.80	150.81	222.25
	8	398.27	150.81	222.25
	11	541.02	150.81	222.25
WD-122 PITCH=203.2 mm	6	406.40	138.11	222.25
	7	468.38	138.11	222.25
	9	594.11	150.81	222.25
WD-480 PITCH=203.2 mm	6	406.40	138.11	279.40
	7	468.38	138.11	279.40
	8	530.86	150.81	279.40
	9	594.11	150.81	279.40
	11	721.36	150.81	279.40

Drag chain sprockets are recommended with a full width tooth to extend chain life. Specify flange width, as the sprockets and idlers are only as wide as the tooth face.

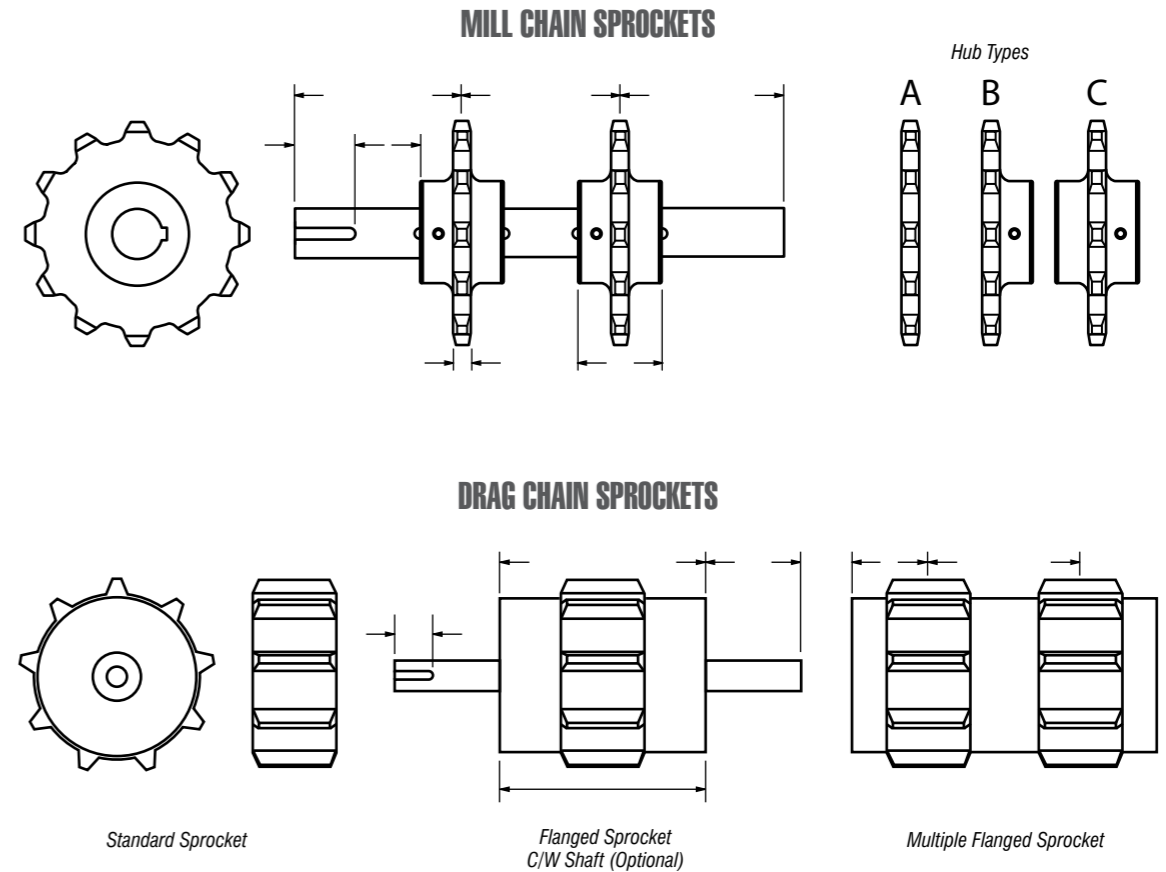

DRAG CHAIN SPROCKETS

ORDER GUIDE								
Qty.	To Fit Chain Size	# of Teeth	Hub Style	Bore	Shaft Fit	Keyway <input type="checkbox"/> STD; <input type="checkbox"/> SPEC	Flanged <input type="checkbox"/> Yes; <input type="checkbox"/> No	Mounted on Shaft
					Sliding or Shrink Fit			Yes or No

STANDARD HUB DETAILS
HUB O.D., KEYWAY & SET SCREW SIZES

1 7/16" Bore	1 15/16" Bore	2 7/16" Bore	2 15/16" Bore	3 7/16" Bore	3 15/16" Bore	4 7/16" Bore	4 15/16" Bore	5 7/16" Bore	5 15/16" Bore
4" OD Hub	4" OD Hub	5" OD Hub	5" OD Hub	6" OD Hub	7" OD Hub	7" OD Hub	8" OD Hub	9" OD Hub	10" OD Hub
3/8" Keyway	1/2" Keyway	5/8" Keyway	3/4" Keyway	7/8" Keyway	1" Keyway	1" Keyway	1 1/4" Keyway	1 1/4" Keyway	1 1/2" Keyway
3/8" x 3/8" S.S.	1/2" x 1/2" SS	1/2" x 1/2" SS	5/8" x 5/8" SS	3/4" x 3/4" SS	3/4" x 3/4" SS	3/4" x 3/4" SS	7/8" x 7/8" SS	7/8" x 7/8" SS	1" x 1" SS

AVAILABLE OPTIONS TO CAN-AM CHAINS

Most CAN-AM products can be ordered with mechanical properties to suit specific or unique applications. Some of the variables are listed below.

1. Non heat treated sidebars or barrels.
2. Through heat treated sidebars, barrels or rivets.
3. Induction hardening of already through hardened sidebars, barrels and rivets
4. Carborized barrels
5. Normalized sidebars and barrels to improve notch toughness for cold weather applications
6. Zinc plated, hard chrome plated, stainless and other rivets in optional steels e.g. 1541, 8620, 4140, 4340
7. Shot peened rivets
8. Prelubricated chain, (molyslip or other)
9. Construction by means of standard riveting, welded rivets, or pins

Note: All standard mill class chains are supplied with heat treated rivets.

WELDING PROCEDURE FOR CAN-AM STEEL CHAIN

Preheat chain and attachments to 93° – 176° C before welding. Preheat temperature is affected by many variables, some are thickness of material, geometry of attachment, and chemical composition of the steel.

1. Use a dry 7018 electrode, or #116 flux core, or wire feed with argon/CO2 shield.
2. Always observe proper welding techniques.

Note: CAN-AM Chains is not responsible for chain, or attachment failure, or welding defects, when ex-factory welding is the cause of the failure or defect, and that welding has been performed by other than our own factory certified welders.

LUBRICATION

Normal chain wear is often the result of friction between the rivet and I.D. of the barrel. Sprocket size and pitch angle will determine the relative motion between parts, and the degree of wear.

Lubrication of these surfaces would lessen wear and slow the progress of corrosion.

Since lubrication significantly reduces the amount of wear to a chain, it would seem to be good economics to pre-lube chain at the point of manufacture and to lubricate that chain throughout its service life. Even a fine spray of water adds to service life.

BREAK-IN PERIOD

Following a proper and logical “break-in” routine will enhance the service life of welded steel chain products.

CAN-AM RECOMMENDS:

1. Chain should be run empty for a period of 6–8 hours, or whatever is practical. A fine spray of water or other lubricant would promote surfaces to polish up.
2. Make sure sprockets are correctly aligned and that wear strip is in good condition.
3. New chain should always be run on new sprockets. Even if the sprockets are only slightly out of pitch, or have even the smallest “hook” to the teeth, those sprockets will dramatically reduce chain life.
4. Check to ensure that chain will not “bind” or “hang up” along the conveyor path.

SIDLIFT LOG HAUL CONVEYORS

The following recommendations will help in the maintenance of existing conveyors and the design and installation of new systems.

1. **Chain Height** – This dimension is controlled by the angle of incline in degrees of the conveyor. The most satisfactory incline is 30 degrees. Using that figure the chain height should be 1/3 the diameter of the largest log expected. In other words a 36” diameter log must have a 12” high chain minimum.
2. **Head End Design** – The sprocket centre must be far enough back from the end of the log haul conveyor to allow for a skid between the top of the sprocket and the end of the log haul conveyor trough. If this were not designed in this manner, the chain could bump it as it travels around on its way back down the sidelift conveyor.
3. **Chain Return** – A catenary return is best for the chains and conveyor structure, and the slack of the chain should be 5-10% of the sprocket centres.

CONVEYOR INSTALLATION AND MAINTENANCE FOR THE FOREST PRODUCTS INDUSTRY

CAN-AM welded steel chains are manufactured of high quality steels, not available “off the shelf” from any steel supplier. These steels, in combination with careful design and expert manufacturing, have produced a high quality chain product that will give superior life and performance when properly maintained.

The recommendations in this catalogue are based on our own experience and observations after almost 40 years of manufacturing chain for the forest products and other industries. The thoughts and suggestions of millrights, maintenance people, engineers, and others have contributed to our philosophy of the maintenance of chain in an industrial environment.

INSTALLATION OF NEW CHAIN IN A NEW CONVEYOR

Check the following:

1. The width of the trough need not be more than 1/2” wider, on each side, than the overall width of the chain including attachments. Chains should not wander from side to side.
2. The wear strip must be full width of the conveyor so that the chain runs on the sidebar, the barrel of the chain does not support the chain itself.
3. Chains that are run in a trough should be at the correct height. Half the height of the sidebar is a good rule of thumb. If the chain is too low, the log or boards will be slowed in their movement. Conversely, a chain running too high in the trough can be easily forced out of the trough by side loads.
4. The root line of the sprocket or drum should be approximately 1/2” above the level of the conveyor wear strip. This allows the chain to be lifted slightly as it contacts the sprocket. The benefits are: immediate contact with the sprocket tooth, rather than 1/3 the way around the drum, and, improved wear life. A low root line relationship between the sprocket and wear strip causes the chain to be pulled down across the end of the wearstrip. This causes premature wear on the sidebars.
5. Be certain the chain has the correct amount of slack on the return. A good rule of thumb for conveyor chain is 5-10% of the sprocket centers depending on the size and weight of the chain.
6. Pay as much attention to the chain return as to the load side. Use a trough if possible. If not, again, the correct amount of slack is important. Too much slack can cause the chain to sway or jump – a condition that increases chain wear.
7. The last step is never to be forgotten for successful operation. Breaking in a new chain is a very important procedure. The chain should be run, no load, for a few hours (6–8). This will smooth up the chain running surfaces as well as the wear strip and the sprocket tooth face and allow rivet OD and barrel ID to polish up. This will ensure maximum life. It is advisable to have a film of clean water on the chain during the break-in period, and for that matter all the time. Water is an excellent lubricant because it will carry away the dirt generated by the chain rubbing the wear strip and sprocket. A fine spray on the chain at the tail end is enough. It is not necessary to have so much water that it makes a mess under the conveyor.

CUT DOWN ON MAINTENANCE COSTS

1. The overall width of the attachment, including the link, should not exceed twice the length of the chain pitch. For example, WR 132 is 6.050 pitch x 2 = 12.1” so, a 13” cradle would be suitable. Anything longer might cause the chain to twist under leverage, and break the link.
2. Head and tail sprockets, when used with attachment chain, should be flanged to locate the attachment when it enters and travels around the sprocket. Flanges are meant only to locate the attachment, not support it. If contact is made, fatigue failures may occur on the attachment welds. Remember to mount the sprocket or idler so that the root line is slightly higher than the wear strip.
3. Flare the trough and return ends slightly to prevent the attachments from hanging up on a squared edge.
4. Wear strips must be full width of the conveyor to support the attachments.
5. The preferred wear strip is a minimum of 450 BHN plate or one of several hardened UHMW products. UHMW, of course, has a very low coefficient of friction, and is best suited for **non-abrasive** locations.
6. Sprocket pitch diameters should be about 4 X’s the chain pitch, for mill chains and 3 X’s the pitch for drag chains. Also, it’s better to use sprockets with an odd number of teeth.
7. Sprocket wear – A hooked sprocket tooth will eventually hold onto the chain beyond it’s normal release point. The worst scenario would have the chain “wrap” the sprocket and break or tear up the drive. Install new chain and sprockets when the chain starts to climb the sprocket tooth, the pitch has now elongated due to wear between the rivet and barrel and possibly elongation of the sidebar hole. This chain will continue to wear itself and the sprocket even more rapidly from this point onward.

Keep the area around tail idlers clear and the idlers themselves turning. Use sprockets if necessary to avoid excess wear on the barrels being dragged around the idler face, if the idler isn’t functioning, for the small difference in cost, it’s always advisable to install sprockets at the tail end of the conveyor.

Keep idlers and drive sprockets aligned.

CONVEYOR CHAIN SELECTION

1. Minimize the number of different sizes of chain in use throughout the mill. Quite often the same chain used on a log deck will also be suitable in a waste conveyor by adding on some weld-on cross flights.
2. Conveyor speeds have increased over the years and the chart below, showing recommended maximum FPM, may be of assistance when selecting conveyor chain. Don’t forget that **Induction Hardened** pins & barrels can **further increase** these maximums. Consult with your CAN-AM factory representative.
Note the effect that a larger diameter sprocket has on the maximum FPM allowable.
If larger sprockets are not practical then often the best answer is to go to a smaller pitch chain. The shorter pitch length will be able to run faster over a given diameter sprocket as its pin & barrel articulation will be less than the larger pitch chain. Also, when reviewing the above, consider using the smaller chain in its XHD version to increase the maximum working load.

MAXIMUM FPM ALLOWABLE

Number of Teeth Sprocket	Pitch in millimeters						
	50.8	101.6	152.4	228.6	304.8	457.2	609.6
6	254	180	147	120	104	85	68
7	297	210	171	140	121	99	80
8	340	240	196	160	138	113	91
9	382	270	220	180	155	127	103
10	425	300	245	200	173	141	115
11	466	330	270	220	190	156	125
12	509	360	294	240	207	170	
13	551	390	318	260	224	184	
14	594	420	343	280	242	198	
15	636	450	367	300	259	212	
16	677	480	392				
17	717	510	416				
18	761	540	440				
19	803	570	465				
20	844	600					
21	886	630					

HEAD END DRIVE FOR CHAIN CONVEYORS

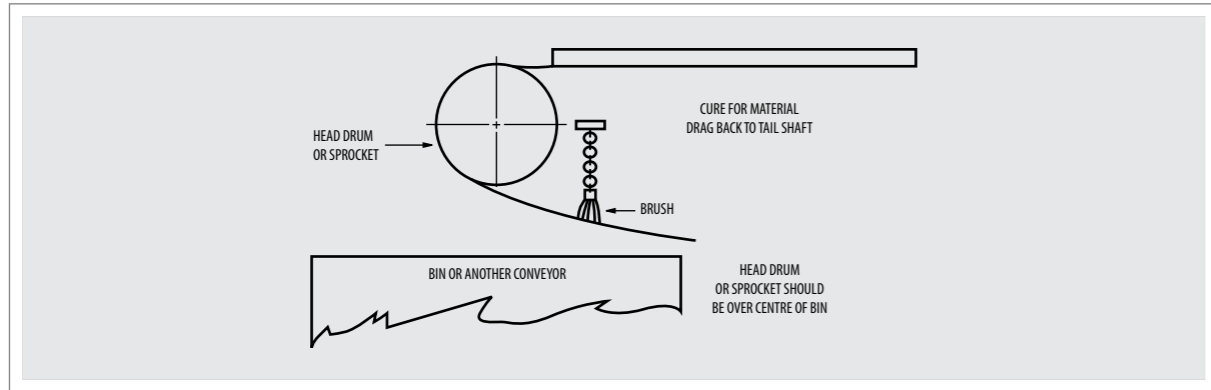

"WATERFALL" DRIVE FOR CHAIN CONVEYORS

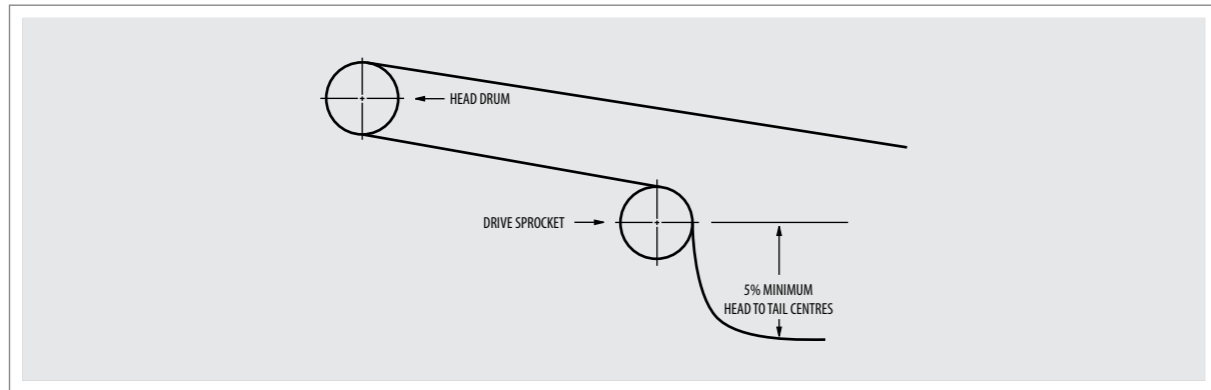

TYPICAL MILL CHAIN DRIVE ARRANGEMENTS

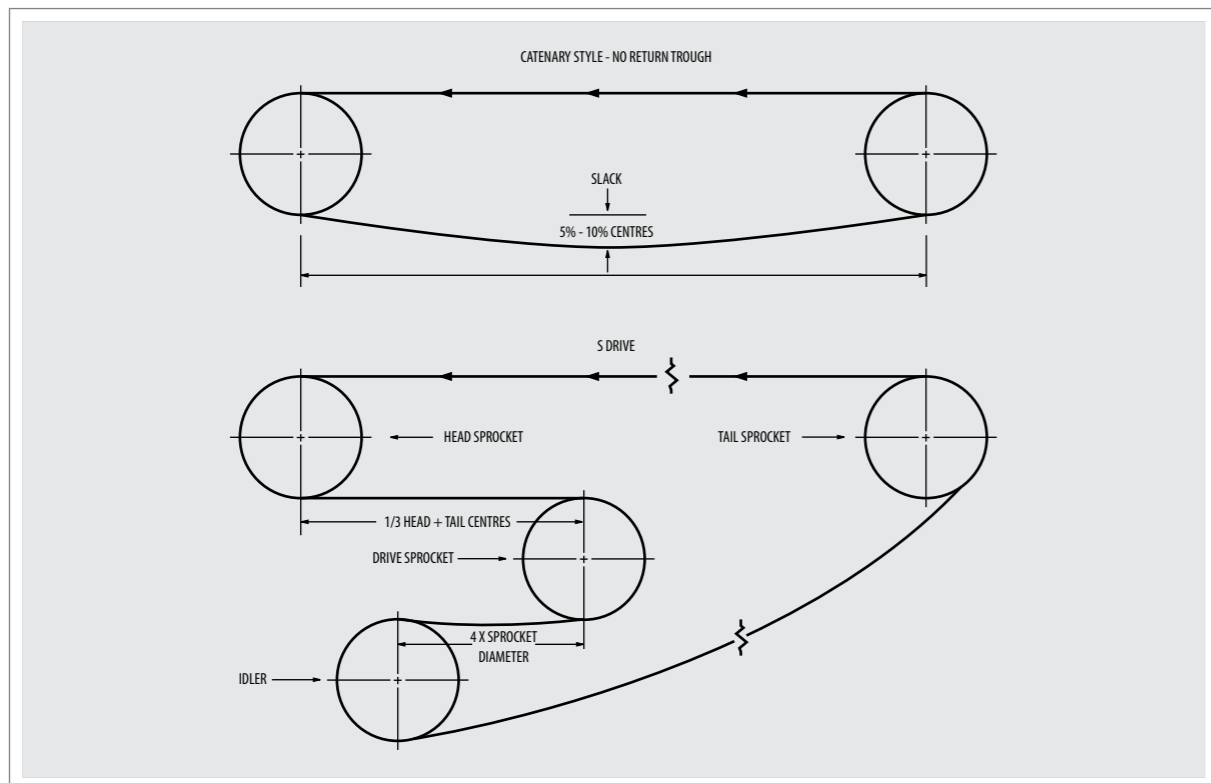

MILL CHAIN FIT IN TROUGH

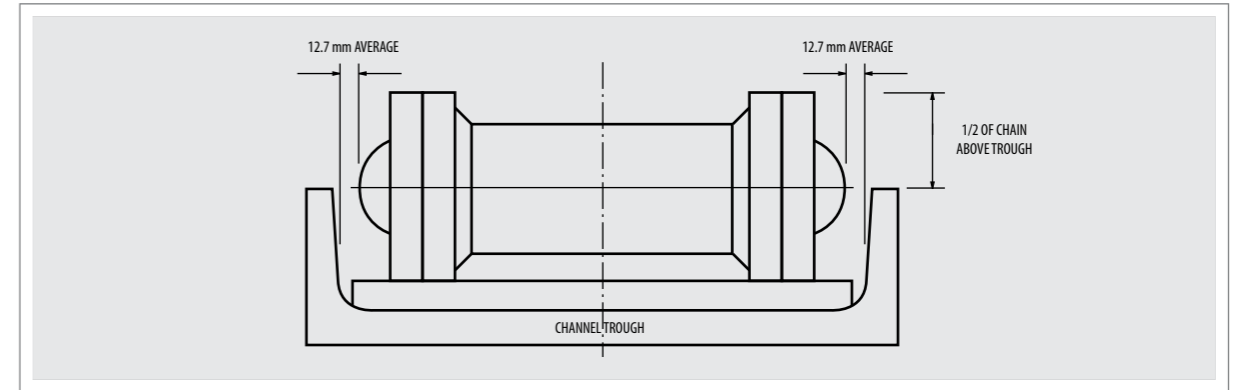

SPROCKET TO TROUGH ALIGNMENT

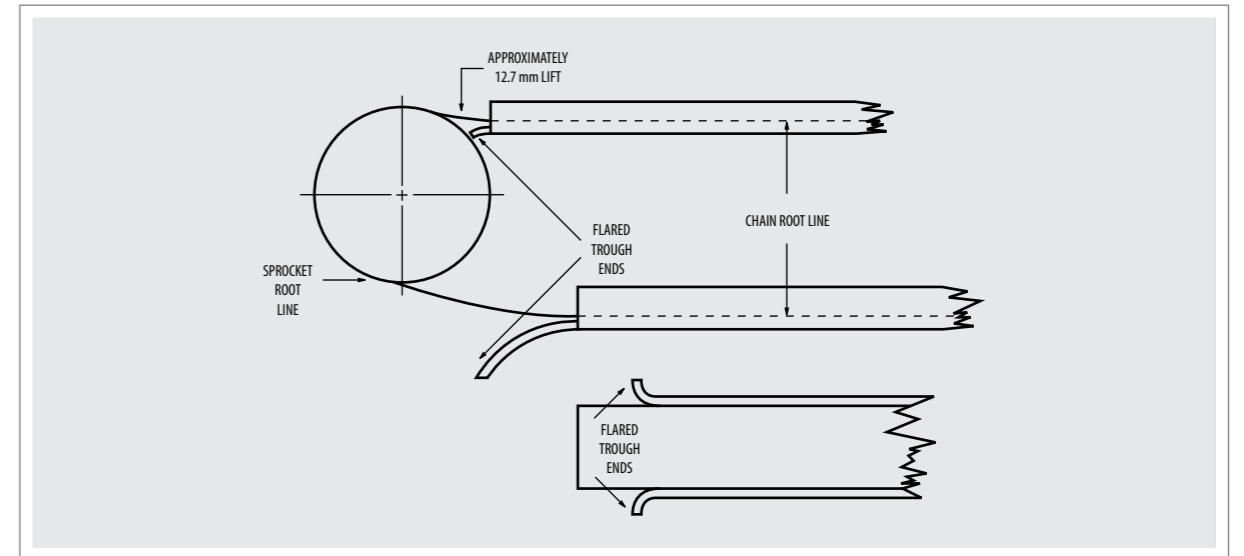

TERMS AND CONDITIONS

General

These conditions supercede those contained in all previous quotations, orders and agreements whether written or oral and shall be the only conditions governing future transactions between the seller and the buyer, unless otherwise specifically agreed to in writing by the seller. Clerical errors are subject to correction. Time is of the essence hereof.

Quotation Period

A quotation is valid for a period of Thirty (30) days from quotation date. It is subject to partial acceptance only upon written consent of the seller.

Delays

Delivery dates are estimates only and are predicated on conditions as known to the Seller at the time of the quotation and the Seller shall not be liable for any direct, indirect or consequential damages due to delays or inability to perform caused by factors beyond its control including but not limited to acts of God, flood, war, riot, fire, accident, explosion, labour trouble, acts of Government, delay or default by subcontractors or suppliers of material or services or transportation difficulties. Delivery dates shall be extended by the period of such delay.

Terms

All orders are subject to approval of Seller's Credit Department. All payments past due shall bear interest at the rate of 1-1/2% per month (equivalent to 18% per annum) until paid. Orders cannot be cancelled or changed or deliveries deferred, except on terms satisfactory to the Seller. If the Buyer fails to pay an installment of the purchase price when due, the Seller may stop work and, at the Seller's option, the entire purchase price shall become immediately due and payable.

Payment

All prices quoted are F.O.B. Seller's plant. Sale shall be deemed complete and the property in the goods pass when the goods are ready for delivery. Goods shall be invoiced when ready for delivery and payment thereof shall be net cash Thirty (30) days from the date of invoice. The Seller reserves the right to alter the terms of payment or to require payment prior to the time of delivery if, in the Seller's opinion, the Buyer's financial condition or other circumstances do not warrant delivery on the terms originally agreed upon.

Taxes

Prices quoted are exclusive of all sales and excise taxes, customs duties or other taxes or levies, and the Buyer is to be responsible therefore.

Shipment

If transportation is quoted, the Seller shall decide carrier and method of shipment unless Buyer's instructions have been agreed to by the Seller prior to quotation. The Seller will not be responsible for any loss or damage to the goods after they are ready for delivery to carrier and the Buyer agrees to assume such risks, insurance premiums, special crating or shipping charges shall be arranged and paid for by the Buyer.

Escalation

Prices quoted are based on correct labour rates and material costs and, if applicable, current freight rates, customs duties, taxes and foreign exchange rates and are therefore subject to change to the extent of any change (either before or after acceptance of this quotation and during the contract period) in any of the foregoing items.

Inspection

If Buyer reserves the right to inspect the goods prior to delivery such inspection shall be made within Seven (7) days of Buyer receiving written notice from Seller that the goods are ready for delivery; otherwise Buyer shall be deemed to have waived all rights of inspection and delivery to the Buyer shall be deemed to be complete at the end of the Seven (7) day period.

Storage and Return of Goods

If the Buyer is unable to remove the goods within Thirty (30) days of their delivery ex Seller's plant, the Seller shall be entitled to charge storage on the goods. Goods cannot be returned except upon Seller's written consent, and will be subject to a restocking charge equal to 25% of the Buyer's invoice.

Patents

The Buyer agrees to save the Seller harmless from all patent infringement claims, liability and expense resulting from the Seller's compliance with the Buyer's specifications or designs now or hereafter forming a part of any work or from written instructions of the Buyer directing the manner in which the Seller shall perform any work.

Applicable Law

Any contract between the Buyer and Seller shall be subject to and construed in accordance with the laws of the state or province wherein the goods were supplied from.

Specifications

In accordance with the policy of the Seller to constantly improve its products, the specifications, designs, and dimensions contained in this catalog are subject to change without notice.

Responsibility

The Seller declines responsibility for any damages incurred as a result of improper installation of attachments installed by firms other than the Seller.

Packaging

Chain is shipped in wired bundles of approximately 10 foot lengths. Any other lengths required shall be made on Buyer's authorisation at time of order.

Dimensions and Weights

Tabular dimensions and weights are approximate and nonbinding. Design improvements may result in variations to published figures. Verification is recommended.

PRODUCTS AND SERVICES PROVIDED BY CAN-AM CHAINS

**SHARP CHAINS
D.L.I. CHAINS
AUTO ROTATE CHAINS**

CAN-AM Chains make a full range of speciality chain and flights to suit all facets of industry.

**CAN-AM FABRICATED
STEEL SPROCKETS**

Normally made of mild steel plate. Heat treated and induction hardened plate sprockets with hardnesses from 360 to 500 BHN are available.

MILL & DRAG CHAIN

CAN-AM's flag ship. We manufacture mill and drag chain for the world.

**SPLIT SLEEVE BEARINGS
2-2500 SERIES**

CAN-AM manufactures a full line of these bearings and stocks them with liners of polyurethane, bronze, babbitt or Zinc Aluminium.

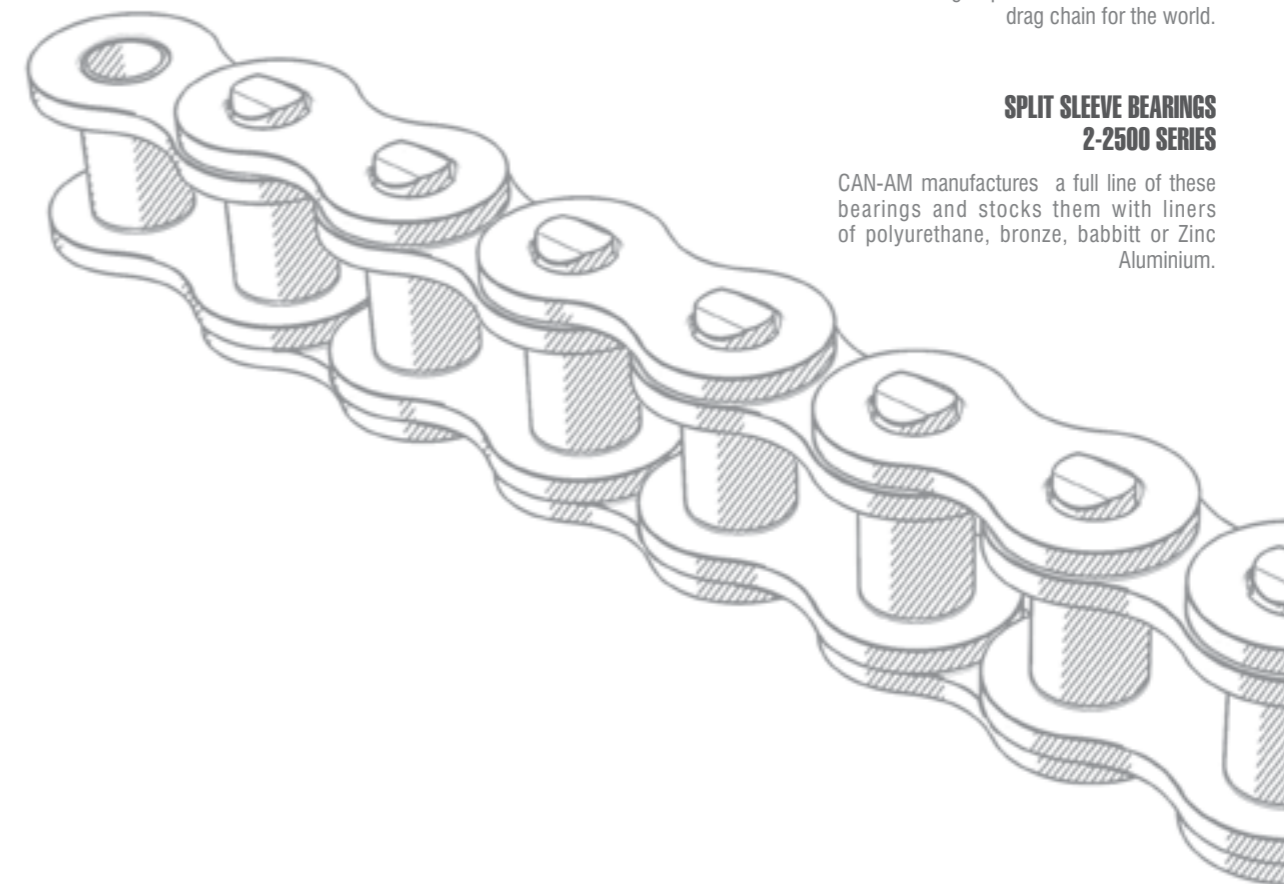

Please contact us for further information or visit our web site at

www.can-amchains.com



CAN-AM CHAINS

Unit 11 Kingfisher Boulevard
Newburn Riverside
Newcastle Upon Tyne
NE15 8NZ

Phone: +44 (0) 191 229 0800
Fax: + 44 (0) 191 908 7371

E-mail: europesales@can-amchains.com
Website: www.can-amchains.com